



BUILDING TRUST



## Installation Procedure

---



### Wabo®SeismaxPlus Wall, NBW-400C thru NBW-2400C Interior Wall/Ceiling Seismic Expansion Joint System

The following installation procedure is very important and must be fully understood prior to beginning any work. To ensure proper installation and performance of expansion joint system the following actions must be completed by the installing contractor. Failure to do so will affect product warranty.

- 1) Carefully read and understand installation procedure. Contact Sika Emseal's Technical Service Department at 508-836-0280 for product assistance.
- 2) Inspect all shipments and materials for missing or damaged components and hardware. Contact Customer Service at 508-836-0280 with Emseal's order number and invoice for prompt assistance.
- 3) Inspect substrate or adjacent construction for acceptance before beginning work. Report unacceptable construction to the project manager for scheduled repair work.
- 4) Review Emseal shop drawings for project specific detailed information if Engineering services were purchased at time of order.

# Health & Safety

During the installation of any Sika Emseal product, appropriate personal protective items should be worn at all times, including but not limited to the following:

- Proper work clothing
- Safety glasses
- Safety boots
- Gloves
- Hard hat



Local rules and regulations regarding safe work environments and health should be followed.

# Product Components

The following components are required for the installation of this product:



Elastomeric Seal  
 P/n: 15340 (Black)  
 P/n: 15341 (Beige)  
 P/n: 15342 (Grey)  
 P/n: 15343 (White)



Aluminum Base Extrusion  
 P/n: 15244



1/4" X 1 1/4" Lg Screw  
 P/n: 5621



Corner Bracket  
 P/n: 20661

Components shown below vary in size depending on model of system:

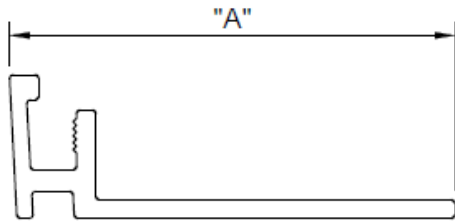

Aluminum Edge Extension  
 (Refer to Chart Below for sizes and P/n)

Model	P/N	"A"
NBW-400C	15800	1 15/16"
NBW-600C/800C	15801	2 15/16"
NBW-1000C/1200C/1800C/2400C	15802	3 15/16"

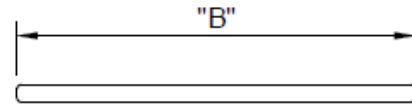

Aluminum Filler Panel  
 (Refer to Chart Below for sizes and P/n)

Model	P/N	"B"
NBW-1800C	15781	2 3/4"
NBW-2400C	15782	4 1/4"



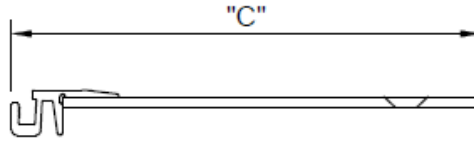

Aluminum Slide Plate  
(Refer to Chart Below for sizes and P/n)

Model	P/N	"C"
NBW-400C	15791	7 5/8"
NBW-600C	15792	11 5/8"
NBW-800C	15793	13 5/8"
NBW-1000C	15795	17 5/8"
NBW-1200C	15796	19 5/8"
NBW-1800C	15797	29 1/8"
NBW-2400C	15798	38 1/8"

## Installation

**1** Prior to beginning work, installer shall inspect for proper wall construction. Verify joint opening as called for on chart.

**Note:** Non-rated wall detail shown below. For rated wall installations, contact project architect to ensure that wall has been properly designed to maintain rating to accept expansion joint and fire barrier systems.

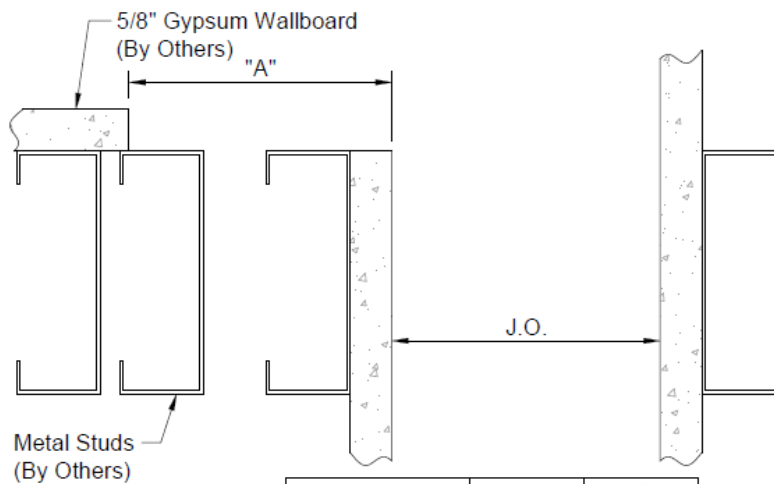

Model	"A"	J.O.
NBW-400C	3 15/16"	4"
NBW-600C	4 15/16"	6"
NBW-800C	4 15/16"	8"
NBW-1000C	5 15/16"	10"
NBW-1200C	5 15/16"	12"
NBW-1800C	7 11/16"	18"
NBW-2400C	9 3/16"	24"



2

**Corner:** For ease of installation, locate corner bracket first. Drill to wall construction and stud. Utilizing drywall screws (supplied by others), mount corner bracket to wall with minimum (4) screws per corner bracket. Place aluminum base extrusion on edge of opening as shown. Utilizing supplied countersink bit, drill through base extrusion at gauge line into stud. Fasten with drywall screws (supplied by others) spaced at 24" O.C. maximum, start 12" from ends.

**Note:** Corner bracket supplied in 24" lengths. For a standard ten foot plate section, (3) corner brackets are required.

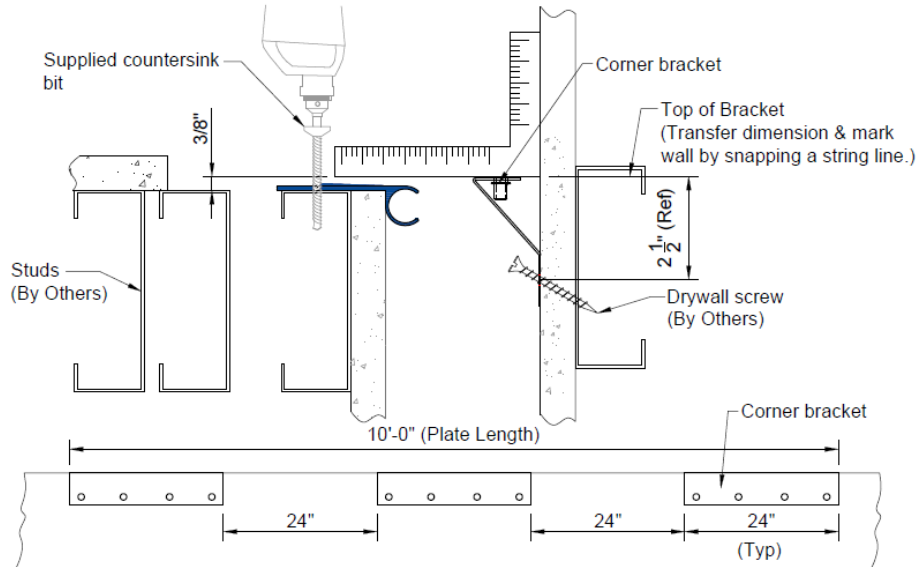

3

Place aluminum edge extension flush with the edge of aluminum base extrusion as shown. Utilizing supplied countersink bit, drill through extension and into stud. Fasten with drywall screws (supplied by others) spaced at 24" O.C. maximum, start 12" from ends.

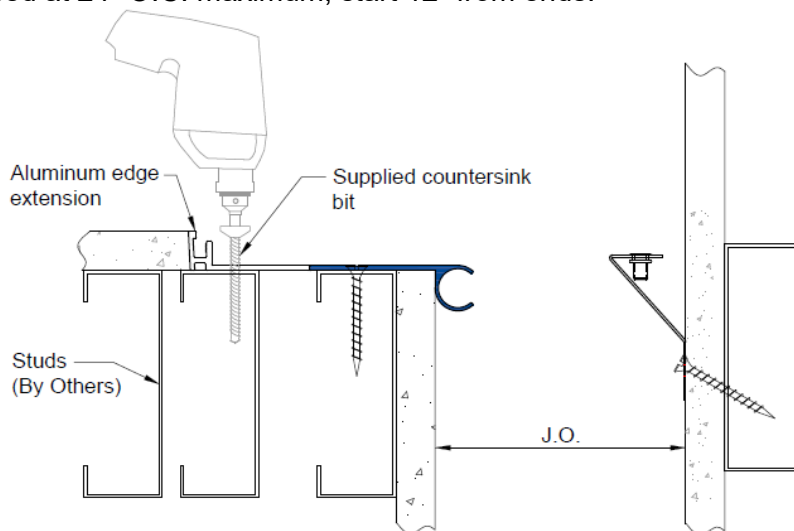

NBW-400C thru NBW-1200C



3A

**Filler Plate:** On NBW-1800 thru NBW-2400 systems, before aluminum edge extension can be installed, filler plates must be inserted flush with the edge of aluminum base extrusion as shown below. Utilizing supplied countersink bit, drill through extrusion and into stud. Fasten with drywall screws (supplied by others) spaced at 24" O.C. maximum, start 12" from ends.

**Aluminum Edge Extension:**

After filler plate has been installed, place aluminum edge extension flush with the edge of filler plate as shown below. Utilizing supplied countersink bit, drill through extrusion and into stud. Fasten with drywall screws (supplied by others) spaced at 24" O.C. maximum, start 12" from ends.

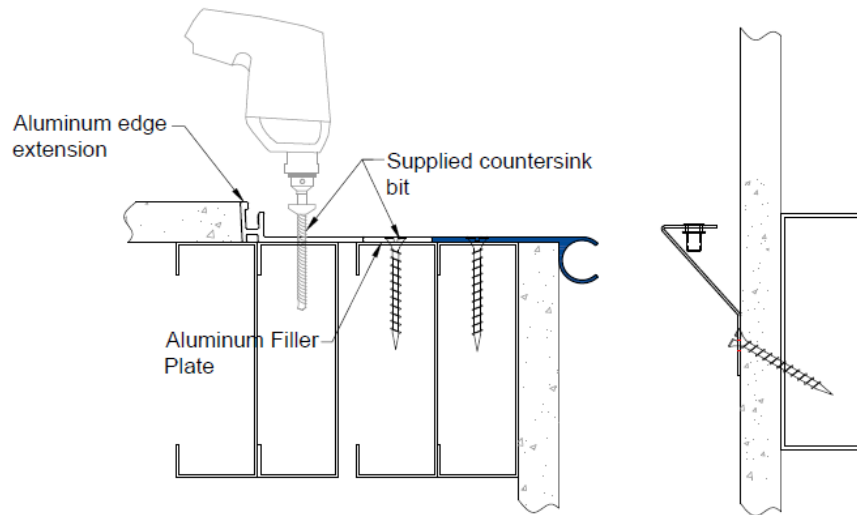

NBW-1800C thru NBW-2400C

4

Position slide plate over expansion opening, Align pre-drilled holes in slide plate with threaded insert in corner bracket. Fasten with 1/4" X 1-1/4" csk flat screw. Tighten to create measurable tension.

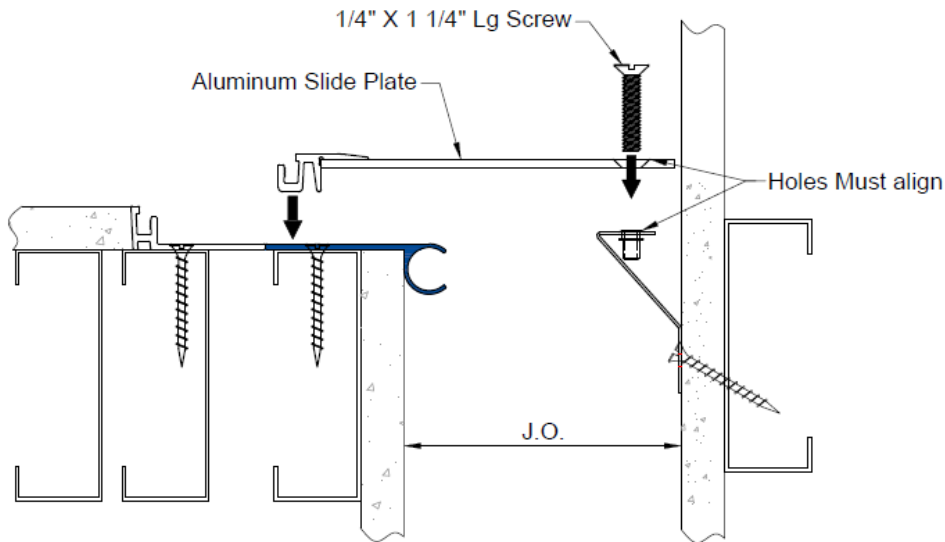

---

**5**

Position seal lug over extrusion cavity and insert lug into cavity, using thumb pressure for initial insertion. Once elastomeric seal is inserted, run thumb along top of lug to ensure complete lug insertion.

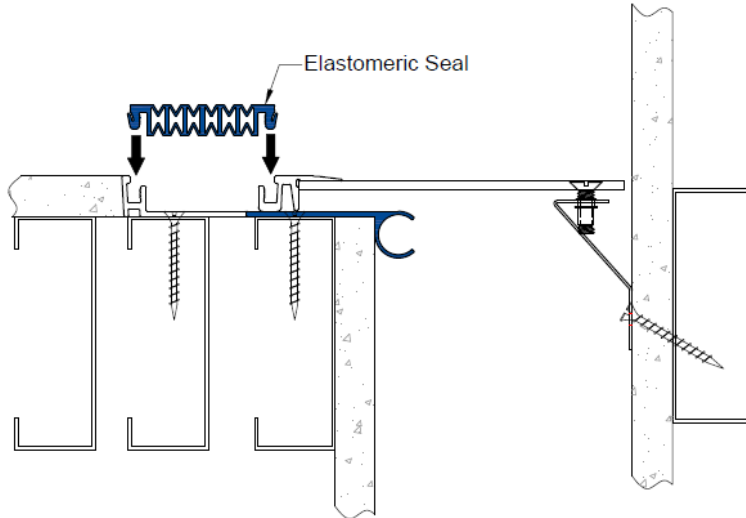

---

**6**

**Optional:** Wipe down aluminum slide plate to remove dust particles prior to applying decorative wall covering materials.

**Caution:** Contact wall covering materials manufacturer to discuss product application and procedure for proper installation. Screw heads should be covered with tape to avoid slot in screw head from telegraphing through wall covering.

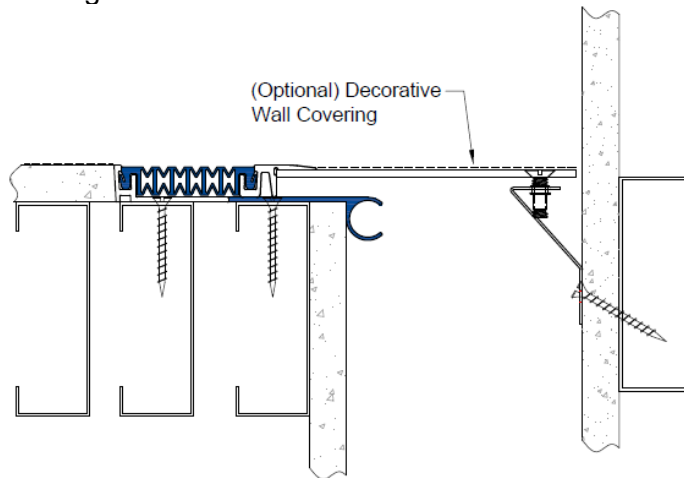

Information provided herein, including but not limited to, any drawing, design, photograph, graphic, or statement(s) ("Materials") are proprietary and the property of Sika Emseal. ("Company"). Reproduction, translation, or reduction to any electronic medium or machine readable form, in whole or part, is strictly prohibited, except for the express purpose for which it has been furnished, without prior written consent of Company. All Materials contained herein are provided by Company for information purposes only. Company reserves the right to amend or withdraw any information contained in the Materials without notice. All technical or other advice by Company, whether verbal or written, concerning products, or the use of products in specific situations ("Advice") is given by Company and is used at the User's own risk.

Sika Emseal  
25 Bridle Lane, Westborough, MA 01581 USA  
Phone: 508-836-0280 / Fax 508-836-0281  
[www.emseal.com](http://www.emseal.com)

Rev. 1.0 04-07-2024

