



XHBN.FF-D-2018 Joint Systems

[Page Bottom](#)

Design/System/Construction/Assembly Usage Disclaimer

- Authorities Having Jurisdiction should be consulted in all cases as to the particular requirements covering the installation and use of UL Listed or Classified products, equipment, system, devices, and materials.
- Authorities Having Jurisdiction should be consulted before construction.
- Fire resistance assemblies and products are developed by the design submitter and have been investigated by UL for compliance with applicable requirements. The published information cannot always address every construction nuance encountered in the field.
- When field issues arise, it is recommended the first contact for assistance be the technical service staff provided by the product manufacturer noted for the design. Users of fire resistance assemblies are advised to consult the general Guide Information for each product category and each group of assemblies. The Guide Information includes specifics concerning alternate materials and alternate methods of construction.
- Only products which bear UL's Mark are considered as Classified, Listed, or Recognized.

Joint Systems

[See General Information for Joint Systems](#)

System No. FF-D-2018

April 08, 2011

Assembly Rating — 2 Hr

Nominal Joint Width — 7 to 10 in.

Class II & III Movement Capabilities — 50% Compression and Extension

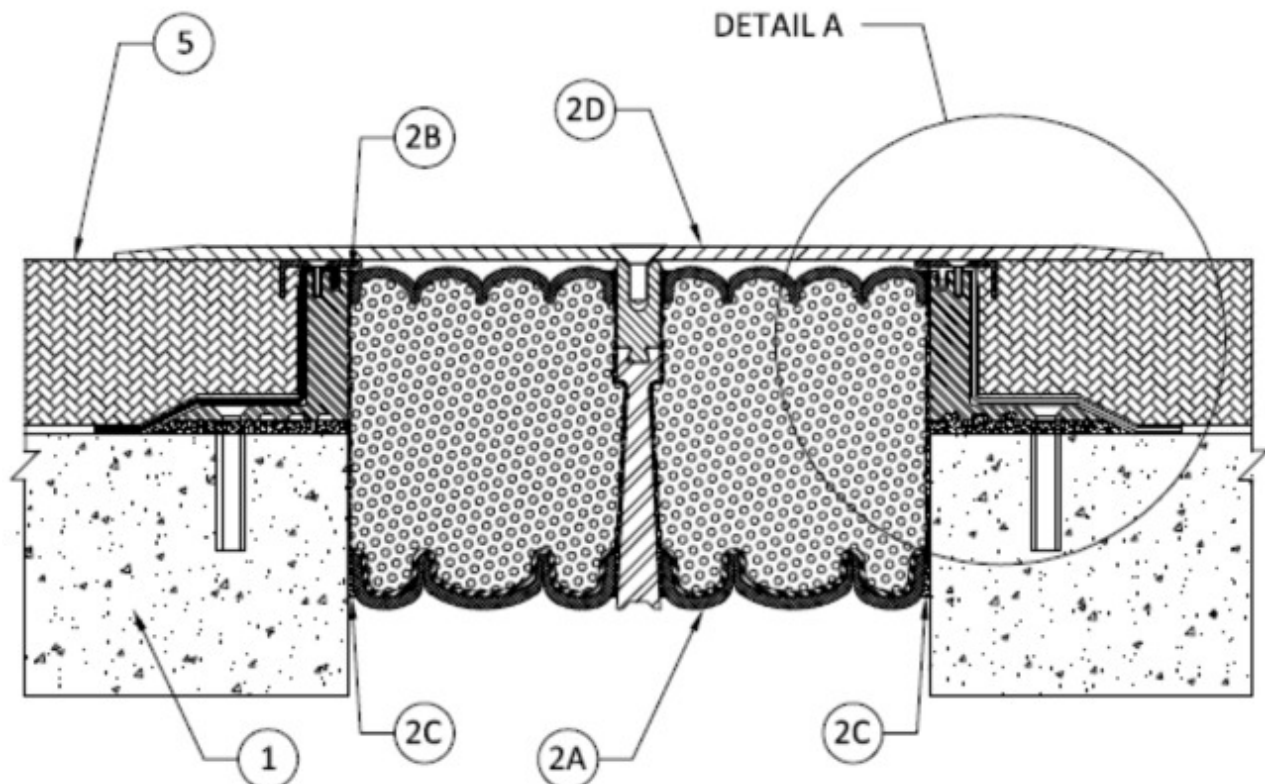

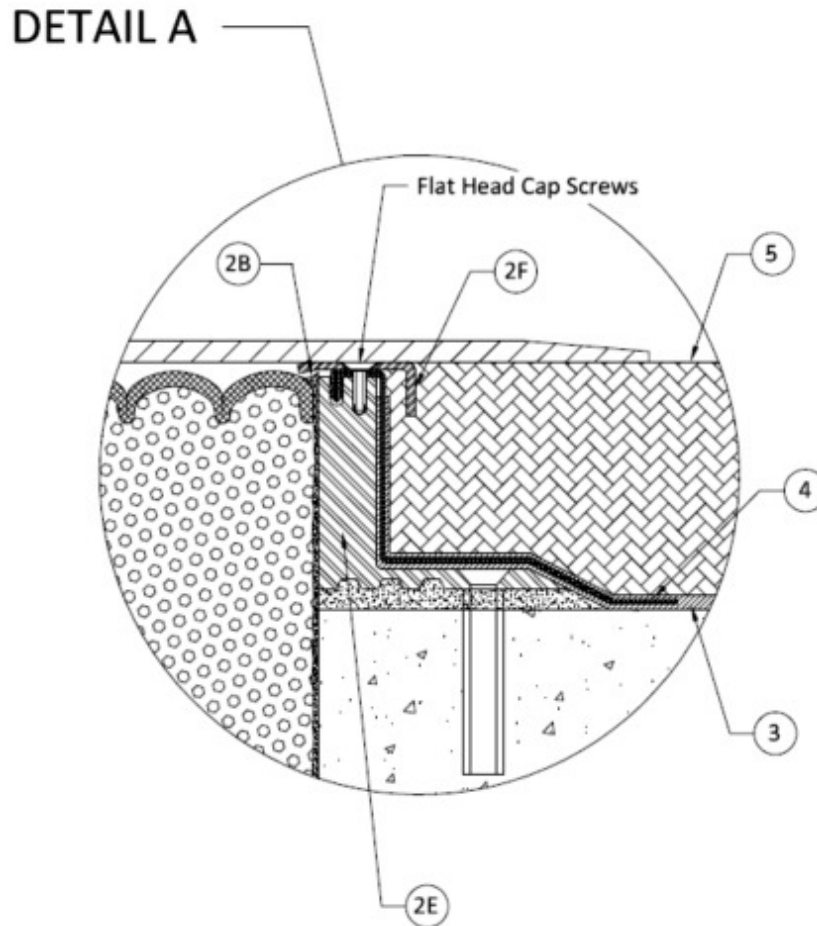

1. **Floor Assembly** — Min 4-1/2" in. (114 mm) thick reinforced normal weight or lightweight (100-150 pcf, or 1600-2400 kg/cu meter), structural concrete.

2. **Joint System** — Nominal width of joint is 7 to 10 in. (175 to 250 mm). The joint system is designed to accommodate a max 50 percent compression or extension from its installed width. The joint system shall consist of the following:

A. **Forming Material*** — Compressed, fire-retardant impregnated, 5-5/16 in. (135 mm) deep foam. Topside of foam is coated with Silicone and underside is coated with intumescent overlaid by a coat of Silicone. Foam is installed in joint opening as a permanent form.

EMSEAL LLC — SJS-FP-FR2 Mechanical joint system.

B. **Sealant Band** — (Optional) — Watertight 3/4 in. (19 mm) deep silicone sealant band and corner bead supplied by joint system manufacturer, and installed in accordance with installation instruction.

C. **Epoxy adhesive** — Consists of two parts; part A (base), and part B (hardener). The epoxy is supplied by joint system manufacturer, and installed in accordance with manufacturer's installation instructions.

D. **Coverplate** — Minimum 1/4 in (6 mm) thick by maximum 18 in (457 mm) Aluminum or Stainless Steel Coverplate. Coverplate is fastened to top of joint system by self-tapping 18-8, (3/8" or 10 mm diam. by 1" or 25 mm long) stainless steel flat head cap screws at 12 in (305 mm) OC.

E. **Aluminum Angle** — Minimum 3 in by 3 in (75 by 75 mm) extruded aluminum angle. Horizontal and vertical legs of the angle are 1/4 in (6 mm) and 11/16 in (17.5 mm) respectively. The underside of the horizontal leg is grooved and placed on a minimum 1/4 in (6 mm) epoxy setting or cementitious curb. The angle is anchored to the concrete slab using 5/16 in (8 mm) diameter, 2-1/2 in (64 mm) long, flat head, counter sunk expansion anchor spaced at 12 in (305 mm) OC. The expansion anchor shall have a minimum clear edge distance of 1-1/8 in (29 mm).

F. **Capping Strip** — Stainless Steel Capping Strip fastened to the Aluminum Angle (Item E) using self-tapping minimum 1/8 in (3.2 mm) diameter stainless steel flat head cap screw at 12 in (305 mm) OC.

3. **Roofing Membrane** — Roofing membrane may be PVC, Hot Rubberized Asphalt, or Rubber.

4. **Side Sheet** — PVC side sheet tied into the Roofing Membrane (Item 3) according to Manufacturer's Install Instructions.

5. **Roof Topping** — Minimum 3 in (75 mm) thick poured concrete, precast concrete, or masonry pavers installed into mortar.

*Bearing the UL Classification Mark

Last Updated on 2011-04-08

[Questions?](#)

[Print this page](#)

[Notice of Disclaimer](#)

[Page Top](#)

[Copyright © 2011 Underwriters Laboratories Inc.®](#)

The appearance of a company's name or product in this database does not in itself assure that products so identified have been manufactured under UL's Follow-Up Service. Only those products bearing the UL Mark should be considered to be Listed and covered under UL's Follow-Up Service. Always look for the Mark on the product.

UL permits the reproduction of the material contained in the Online Certification Directory subject to the following conditions: 1. The Guide Information, Designs and/or Listings (files) must be presented in their entirety and in a non-misleading manner, without any manipulation of the data (or drawings). 2. The statement "Reprinted from the Online Certifications Directory with permission from Underwriters Laboratories Inc." must appear adjacent to the extracted material. In addition, the reprinted material must include a copyright notice in the following format: "Copyright © 2011 Underwriters Laboratories Inc.®"

An independent organization working for a safer world with integrity, precision and knowledge.

