



# EMSHIELD DFR2 & DFR3 SYSTEMS INSTALL DATA

DO NOT OPEN ANY PACKAGES or install this material until all members of your crew have read and understand these instructions as well as all relevant MSDS sheets. If you do not understand any part of these instructions CALL EMSEAL: 800-526-8365 or 508-836-0280

This document does not purport to address all of the safety concerns, if any, associated with this product's use. It is the responsibility of the user of this document to establish appropriate safety and health practices and to determine the applicability of regulatory limitations prior to use. The use of a dust mask, safety goggles and gloves is recommended. Keep out of reach of children.

**IMPORTANT: This product cannot perform its intended function if not properly installed.**

# A T A

## 1 Equipment & Material Storage

In addition to safety equipment required to comply with applicable federal, state and local safety regulations, equipment to prepare and repair the joint-faces, as well as normal tools of the trade, the following are required:

### Equipment Checklist:

- Tape measure
- Mixing paddle and heavy-duty, low-speed drill for mixing epoxy adhesive
- "Sausage" caulking gun & tips for silicone sausages
- Caulking gun for 10-oz silicone tubes
- Large tube-caulking gun for intumescent caulk tubes provided
- Long-bladed, serrated bread knife
- Hacksaw
- Miter box or miter block
- Spray bottle with water
- Duct tape (2 ½ times the length of joint)
- Spatula to scrape epoxy from can
- Chemical-resistant gloves
- 2-inch wide (50mm) margin trowels for applying epoxy adhesive on the material and for spreading intumescent sealant on exposed foam face.
- Caulk knives for tooling sealant bands
- Toluene for cleaning joint-faces, trowels and mixer tools
- Clean lint-free, 100% cotton rags

**Cold Days:** Store Sealant, off the floor, inside at above 68°F (20°C). It will recover slower when cold and faster when warm.

**Very Hot Days:** Keep sealant out of direct sun when the temperature is greater than 60°F (15°C) until immediately prior

## 2 Prepare & Solvent-Wipe Joint Faces

### Concrete:

- Remove loose particles and weak concrete to ensure sound concrete substrate. Spalls, chipped edges and uneven surfaces must be repaired using suitable patching material and proper patching geometry and techniques. Joint faces must be parallel.
  - Joints must have unobstructed depth greater than or equal to the full depth of the largest material supplied plus 1/2-inch (6mm).
  - Remove all contaminants by sandblasting or grinding to ensure a thoroughly clean and sound substrate for the full sealant depth.
- NOTE: DO NOT use a wire wheel—this will polish the substrate and cause bond-failure.**
- Dry all wet surfaces.
- NOTE: Do not use flame to dry substrate—this will leave carbon on the substrate and cause bond-failure.**
- Wipe joint faces with solvent-dampened, lint-free rags to remove all concrete dust and contaminants.

**Other Substrates:** Contact EMSEAL.

## 3 Measure Joint Width & Find Correct Size Material

- Measure joint width at deck surface and below to ensure joint faces are parallel.
- Material has been supplied to suit your mean temperature field-measured joint widths. Widths of material supplied are marked on each stick of material. Find correct box and open it.
- Compare width of material supplied as marked on each stick against mean joint width. Actual width of material as measured between hardboard will be slightly less than marked size because material is over-compressed for ease of installation.

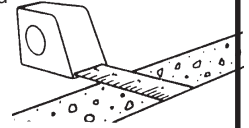

**NOTE: If unsure of correct material selection, consult EMSEAL.**

**IMPORTANT: Do not remove outer plastic packaging until you have read and understand the rest of these instructions as material may expand prematurely.**

## 4 Mask Deck & Mix Epoxy Adhesive

- Using duct tape, tape off the deck on both sides of the joint.

### Mix Epoxy

- EMSEAL epoxy adhesive may be used in the 41°F (5°C) to 95°F (35°C) temperature range.
- Using a trowel, transfer the entire contents of Part B (hardener) into the contents of Part A (base).
- Mix the material thoroughly with a drill and mixing paddle. Scrape the walls and bottom of the container to ensure uniform and complete mixing.
- Always mix component B (hardener) into component A (base). Ensure that a uniform gray color with no black or white streaks is obtained.

**IMPORTANT: DO NOT thin the epoxy.**

- **Precaution:** Wear chemical-resistant gloves and/or barrier hand cream when handling liquid sealant or epoxy. Remove promptly from skin with a commercial hand cleaner before eating or smoking. Avoid inhaling vapors.

## 5 Apply Epoxy to Substrate, Unwrap DFR

Ensure that the mixed epoxy adhesive is applied to the substrate before the pot life has expired (10 - 30 minutes depending on the ambient temperature).

**WARNING:** Epoxy will harden more quickly when left in the pot. Apply it onto the joint face as soon as possible.

**IMPORTANT:** The epoxy must still be uncured when installing DFR foam into the joint-gap.

If the epoxy cures before installing the DFR foam then reapply new epoxy. If work is interrupted for more than 2 hours after initial cure then grind the old epoxy and apply new wet epoxy.

**IMPORTANT:** While one or more workers are applying epoxy to the joint faces, others must prepare the DFR foam. The DFR foam is kept under compression by plastic wrapping and hardboard on both sides.

- Slit the plastic packing by cutting on the hardboard and remove hardboard and inner release liner. DO NOT cut along the silicone bellows face or the red intumescent bellows face.

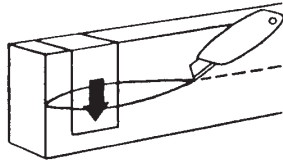

**IMPORTANT:** Work quickly and deliberately after cutting the shrink-wrap to avoid material expanding beyond a usable size.

## 6 Wipe Release Agent off Silicone Facing of DFR2 Foam

- For packaging and production reasons, the silicone facing is coated in the factory with a release agent.
- Prior to installation, this agent must be wiped off in order for the injected sealant bands described in Step #9 to adhere to the silicone facing and to avoid contamination of the substrate at this point.
- Lightly, quickly and thoroughly wipe the cured silicone facing with a lint-free rag made damp with water to remove the release agent.

**TIP:** Use the hardboard packaging as a flat, clean working surface.

- Clean Up:** Remove epoxy and silicone sealant from equipment before it cures using MEK\*\*, Toluene\*\*, or Xylene\*\*. These solvents are not effective after the epoxy or silicone has cured. Cured material may be removed by cutting it away with sharp tools, sandpapering or softening with chlorinated solvents\*\*. \*\* (Solvents mentioned or referred to are toxic and flammable. Observe solvent manufacturer's precautions and refer to Material Safety Data Sheets as well as local and federal requirements for same handling and use).

## 7 Install First DFR Foam Length into Joint & Apply Silicone to Bellows Face

- Identify the traffic (top) and fire (bottom) side of the foam and install in the correct direction. The top will have only a smooth silicone bellows. The bottom will always have a layer of a rough red intumescent bellows coating.

**Note:** In some cases if specified by the architect, there may also be a layer of smooth silicone covering the red intumescent on the bottom side.

**IMPORTANT:** Always install DFR2 and DFR3 sticks with the red intumescent side facing down into the gap.

- Immediately install the foam into the joint. Ensure that epoxy on the joint face has not cured.
- When installed, the DFR2 and DFR3 must be recessed so that the top of the bellows is flush or slightly below the deck surface.
- Note: When material is correctly expanded for a snug fit it will support its own weight in the joint.
- Feed material into joint, starting from one end. The material should fit snugly and must be eased into the joint with steady, firm pressure.
- Leave the end to be joined to the next length sticking slightly proud of the joint.
- Repeat step #6 for each new stick.
- On the end of the next stick, using a bulk gun and the sausages of silicone provided, apply the liquid silicone to the exposed face of the silicone bellows.
- Using a large caulk gun and the tube of intumescent sealant provided, apply the intumescent sealant to the exposed face of the intumescent bellows and to the exposed face of the foam.
- Use a caulk knife or margin trowel to spread the intumescent sealant over the face of the foam to an even 1/16th-inch (2mm) thickness.

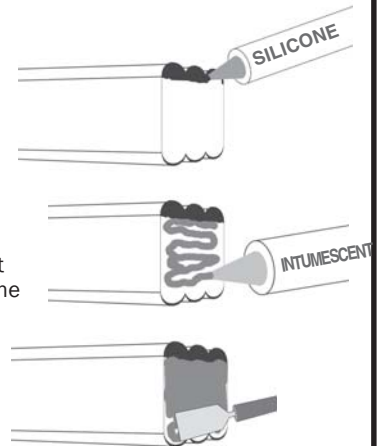

**IMPORTANT:** All sticks of DFR2 and DFR3 foam MUST have a coating of intumescent on the faces of all joints. This ensures that joints do not compromise the fire barrier.

## 8 Install Next Length. Repeat.

- Work in one direction towards the previously installed length or end of joint. Do not stretch material.
- Leave the end to be joined to the previous length sticking proud of the joint—push the joining faces together.
- Push Hard** on the stick to compress joints firmly together. Ensure there are no voids at joints.
- Once the full length is installed, push the protruding joint into the joint and tool off the excess silicone.
- During low temperature installation, provide as much ambient heat as possible around installed DFR foam to accelerate recovery.

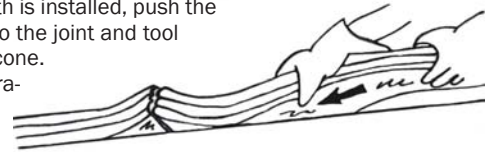

## 9 Inject Silicone Sealant Bands at Substrates & Tool Excess Silicone

- Wipe any excess epoxy from top of material using a clean rag.
- Before the epoxy cures, force the tip of the silicone caulk gun between the substrate and the DFR foam. Inject a 3/4-inch (20mm) deep silicone sealant band between the foam, cured silicone facing and the joint-face.
- Tool the freshly applied silicone firmly to blend with the substrates and cured silicone facing, and to ensure a proper bond and seamless appearance.

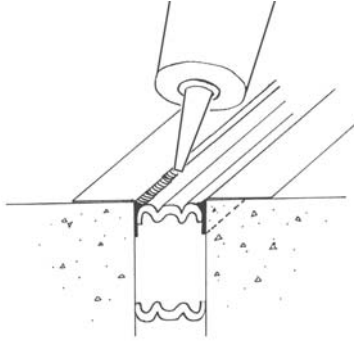

- Where DFR foam meets at butt joints, tool the excess silicone that squeezes out from the top and between the bellows. **IMPORTANT: Silicone left between the wrinkles of the bellows could constrain movement – using a caulk knife, remove excess sealant and blend what remains into the bellows.**
- **Note:** Silicone sealant band is only applied to the weather side of the DFR foam.

### SILICONE-COAT ANY EXPOSED FOAM ENDS:

**IMPORTANT:** Any stick of DFR2 or DFR3 which finishes with an open end, not terminating into another stick or structural termination, must be lightly coated on the exposed foam end using the liquid silicone sealant provided. This is critical to ensure that the fire-retardant impregnated foam is sealed.

## NOTES

### Design/System/Construction/Assembly Usage Disclaimer

This material has been tested to UL/ULC 2079 and is manufactured under UL's Follow-Up Service. The material is being supplied as a fire-rated component of a wall or floor assembly. It has been tested to UL 2079 in assemblies as depicted in EMSEAL's various listings in the UL Online Certifications Directory. The published information in these listings cannot always address every construction nuance encountered in the field. Authorities Having Jurisdiction should be consulted in all cases as to the particular requirements covering the installation and use of UL Listed or Classified products or materials. Authorities Having Jurisdiction should be consulted before construction to ensure that specific adjacent substrates and assemblies are detailed and constructed to meet local fire-rating requirements.