



## BG SYSTEM

Expansion joint for blind-side formed floors and walls.

# PRODUCT/INSTALL DATA

### Product Description

- The BG System is a heavy-duty, double-celled, extruded, thermoplastic rubber gland flanked by integral side flashing sheets.
- The system consists of:
  - 1) Thermoplastic (heat-weldable) BG sealing insert and side flashing sheets
  - 2) Termination bar and anchors
- The above components are combined in the field with a waterproofing membrane and accessories offered by the waterproofing membrane manufacturer for use in blind forming conditions.
- The waterproofing membrane is installed on the mud-slab or lagging in accordance with the waterproofing membrane manufacturer's instructions.
- The BG SYSTEM sealing gland is positioned over waterproofing membrane at the centerline location of the structural expansion joint.
- The underside of the BG SYSTEM side flashing sheets are adhered to the installed waterproofing membrane using an adhesive mastic provided by the waterproofing membrane manufacturer as tested and approved for this purpose.
- Another layer of the adhesive mastic is applied over the top of the BG SYSTEM side flashing sheets to a width which is wider by at least two inches than the BG SYSTEM side flashing sheets.
- Another full width layer of waterproofing is firmly, and without any voids, adhered into the adhesive mastic thereby completing a sandwich of the BG SYSTEM side flashing sheets and the waterproofing membrane and adhesive mastic.
- The BG SYSTEM termination bar and anchors are installed to hold the system in place prior to pouring concrete.
- The concrete is poured over the waterproofing membrane and BG SYSTEM sandwich.
- The net result is the integration of the below-grade waterproofing membrane and expansion joint system on the positive side (the side that water reaches first) of the wall or floor while ensuring that movement at the joint-gap is properly accommodated.

### Uses, Applications

- For use at structural expansion joints in foundation and tunnel floor and wall slabs where access to the positive side is not possible after casting.
- Suitable for installation where access to the positive side of walls is impossible, such as in:
  - 1--lagging or single-side forming conditions
  - 2--across the underside of foundation and tunnel slabs.
- Where access to walls roof slabs is possible, the BG SYSTEM would be used on the underside of the floor slab only. A factory-fabricated upturn from the BG SYSTEM would be welded to the components of

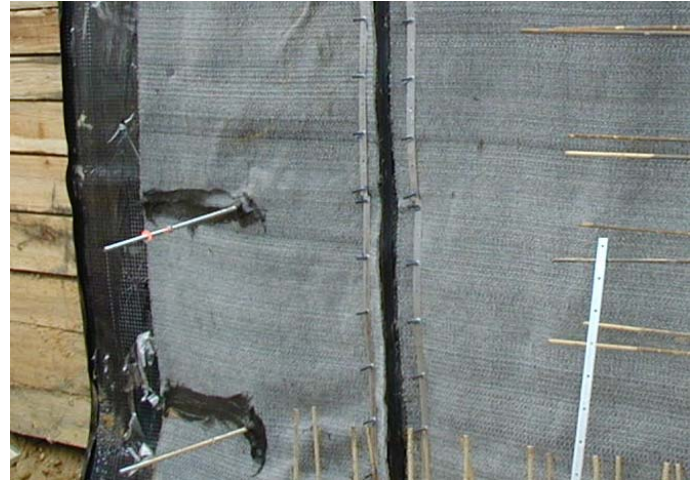

the full MIGUTAN FP 110/25 (consult EMSEAL) for use on the walls, which in turn would be welded to the sealing components of the MIGUTAN FP 110/... best suited to the design requirements of the roof slab.

### IMPORTANT:

The BG System is, in concept, a solution to the difficult problem of sealing expansion joints on the positive side of blind-side formed foundation conditions created through the choice or need to cast concrete against lagging rather than casting freestanding foundation walls.

The specification of the BG SYSTEM is made as a consequence of the designer's recognition of the merits of the principle of the BG SYSTEM solution. Likewise specification of the BG SYSTEM is made with the designer's and owner's understanding of the need for proper installation and control and protection of the system throughout the construction process.

EMSEAL assumes no responsibility and supplies no warranty for the workmanship of the contractors involved in any part of site preparation and/or installation of the BG SYSTEM, or for the finishing of any part of the related work on any project.

The BG SYSTEM will not perform in conditions that are unsuitable to the requirements for performance of the waterproofing membrane materials into which the BG SYSTEM is integrated (consult the waterproofing membrane manufacturer).

**Ultimately, because the BG SYSTEM is heavily dependent on proper workmanship during installation, and protection after it is installed and before and during concrete placement, EMSEAL offers no warranties for watertightness and the specification and use of the BG SYSTEM is strictly at the designer and owner's risk and discretion.**

**Limited Warranty:**

EMSEAL Joint Systems, LTD. (hereinafter "EMSEAL") warrants the BG SYSTEM to be free of defects in workmanship-in-manufacture and materials only at the time of shipment from our factory. If any BG SYSTEM materials are proven to contain manufacturing defects that substantially affect their performance, EMSEAL will, at its option, replace the materials or refund its purchase price.

THIS LIMITED WARRANTY IS THE ONLY WARRANTY EXTENDED BY EMSEAL WITH RESPECT TO THE BG SYSTEM. THERE ARE NO OTHER WARRANTIES, INCLUDING THE IMPLIED WARRANTIES OF MERCHANTABILITY OR FITNESS FOR A PARTICULAR PURPOSE. EMSEAL SPECIFICALLY DISCLAIMS LIABILITY FOR ANY INCIDENTAL, CONSEQUENTIAL, OR OTHER DAMAGES, INCLUDING BUT NOT LIMITED TO, LOSS OF PROFITS OR DAMAGES TO A STRUCTURE OR ITS CONTENTS ARISING UNDER ANY THEORY OF LAW WHATSOEVER.

**Availability & Price**

EMSEAL products are available throughout the United States and Canada. Prices are available from local representatives or direct from the manufacturer. The EMSEAL product range is continually being updated. Accordingly, we reserve the right to modify or withdraw any product without prior notice.

**INSTALLATION--GENERAL:**

There are basically three blind conditions in which the BG SYSTEM can be installed:

- 1) On the underside of the floor-slab (on top of a mud slab) of a foundation or tunnel with freestanding walls
- 2) Under the floor-slab AND on the walls of a blind-side formed (lagging retaining system) foundation or tunnel.
- 3) On the walls only of a blind-side formed (lagging retaining system) foundation (no joint in floor slab).

**IMPORTANT:**

The BG SYSTEM is not for use on freestanding walls where access to the wall is available. For these conditions install the complete MIGUTAN FP 110/25 expansion joint system.

**IMPORTANT:**

The BG SYSTEM will not perform its intended function if installed on rough and irregular surfaces. Substrates similar to rock, earth, chain-link retaining mesh, etc. that are not lagging ARE NOT acceptable substrates for the BG SYSTEM. In addition, the use of drainage board as a means to smooth irregular surfaces is not acceptable. If drainage board is specified, the substrate that will support the drainage board must be smooth, lagged walls.

**SUMMARY:**

There are several basic principles that apply throughout the use of the BG SYSTEM.

- 1) The waterproofing membrane shall have been determined by the manufacturer of the membrane to be compatible with and have a proven method by which to adhere positively and permanently to the BG SYSTEM material of manufacture.

- 2) The waterproofing membrane shall be installed continuously across the mud-slab and/or lagging walls;
- 3) A continuous strip of waterproofing membrane will be centered over the position of the expansion joint on the wall and/or floor slab;
- 4) The BG SYSTEM side sheets shall be installed without any folds, "fish-mouths" or wrinkles, into a wet waterproofing membrane mastic suitable to adhering the BG SYSTEM side sheets to the waterproofing membrane. The waterproofing membrane mastic is to be applied to a width wider than the BG SYSTEM flashing sheets by at least 2" (50 mm). The waterproofing membrane mastic is to be applied both below the BG SYSTEM flashing sheets as well as above the BG SYSTEM flashing sheets so as to completely encapsulate the BG SYSTEM flashing sheets.
- 5) All BG SYSTEM flashing sheet transitions from floor to wall must be fully encapsulated (above and below) in waterproofing membrane mastic.
- 6) The BG SYSTEM flashing sheets and wet waterproofing membrane mastic shall be covered by another full-width strip of waterproofing membrane on each side of the belly of the BG SYSTEM gland.
- 7) The entire BG SYSTEM/waterproofing membrane sandwich shall be clamped into place using EMSEAL supplied termination bar and protruding-head anchors.
- 8) The BG SYSTEM/waterproofing membrane sandwich shall have concrete cast directly against it.
- 9) The BG SYSTEM shall transition into the MIGUTAN plaza deck joint system on the roof slab or shall be suitably transitioned into the above-grade wall joint system in the building face.
- 10) The ultimate objective is to ensure continuity of seal around the complete structure as shown below:

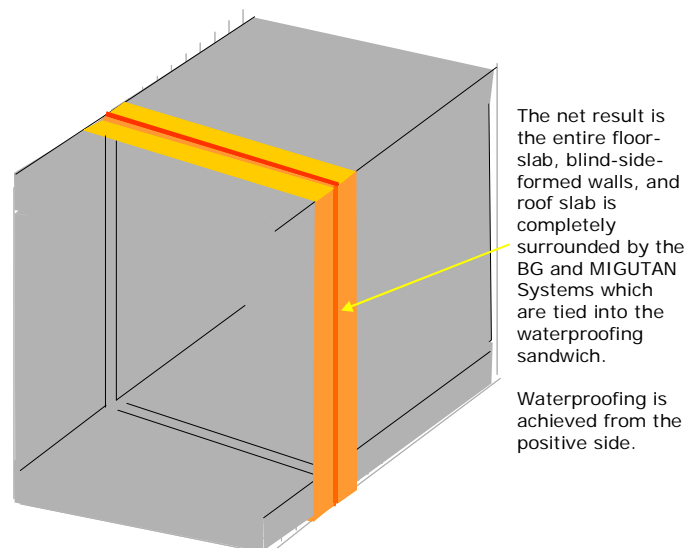

## EQUIPMENT LIST

(In addition to normal tools of the trade and safety equipment, as well as tools and materials required by the manufacturer of the waterproofing membrane, the following materials and equipment must be on-site before installation can begin):

### For Preparing and Drilling Mud-Slab Concrete

- 4-inch angle grinder(s) with diamond cup blade(s)
- minimum 2 ea - Hammer drills with depth guides
- minimum 6 ea - Hammer drill bits, 3/16-inch (5 mm) diameter, suitable for masonry/concrete
- Generator, fuel, and accessories or access to reliable high-amperage power source

### For Cutting Termination Bar

- hacksaw

### For Driving Screws

- Electric drill/driver. (minimum 14.4 volt cordless works well)
- minimum 6 ea - #3 screw-gun bits

### Other Miscellaneous Tools and Materials

- 100-foot (30 meter) tape measure (or length to suit project)
- chalk box with chalk
- Flat bar and small pry bar
- 5-gal pail of toluene or xylene (depending on the size of the job, less may be adequate)
- box of clean, dry, lint-free, cloth (not paper) rags
- extension cords with 4-way box

## INSTALLATION:

### STEP 1: Unroll Sealing Gland and Prepare Floor and Wall Surfaces

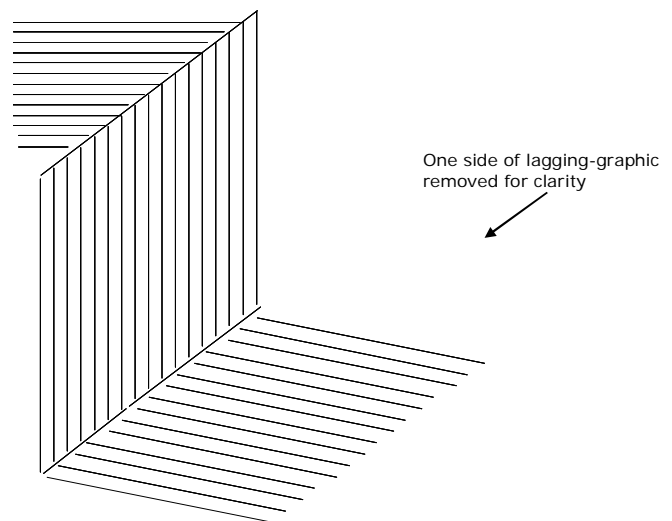
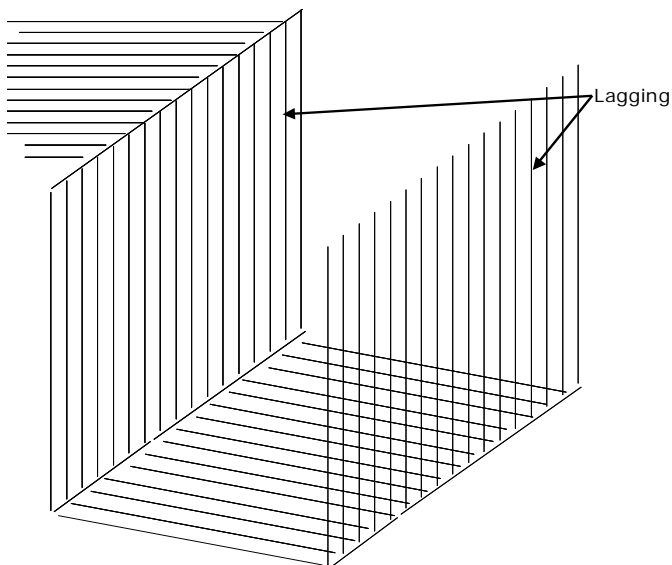

**IMPORTANT:** The BG SYSTEM is not for use on freestanding walls where access to the wall is available. Where access to the positive side of the wall is available, use the MIGUTAN FP 110/25 expansion joint system.

Unroll the sealing gland belly-side up in a clean open space to allow the rubber to relax from its coiled shipping state.

Prepare concrete surfaces as required by the waterproofing membrane manufacturer.

Note: If drainage board is specified to be installed against the lagging or shot-crete wall, install it first in accordance with the instructions of the waterproofing manufacturer and/or drainage board manufacturer as applicable.

**IMPORTANT:** Using drainage board as a means to creating a smooth substrate is NOT ACCEPTABLE. The surfaces that will support the drainage board must be smooth, lagged walls.

**STEP 2: Install Waterproofing Membrane on Mud-Slab and Wall Upturn**

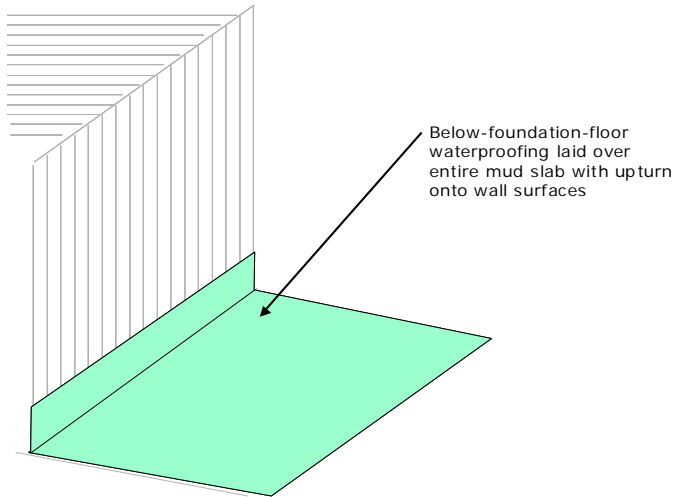

Install waterproofing membrane over entire mud slab with an appropriate upturn onto wall surfaces in accordance with waterproofing membrane manufacturer's procedure.

**STEP 3: Apply Waterproofing Membrane Adhesive Mastic**

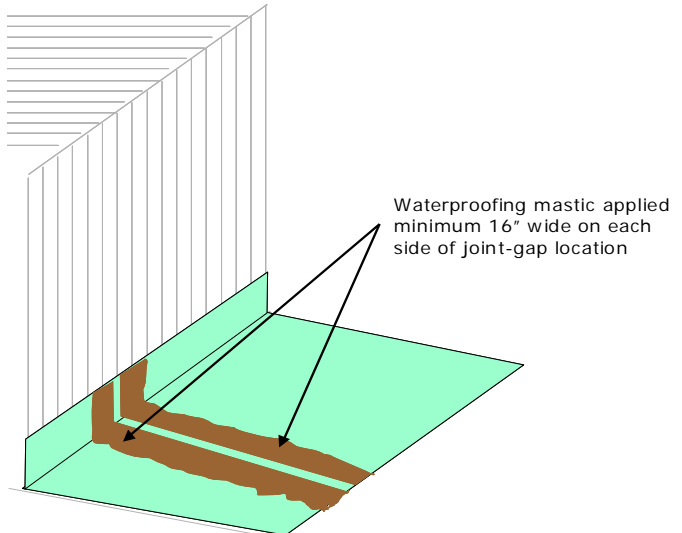

Apply waterproofing membrane adhesive mastic onto the waterproofing membrane on the floor and wall-upturn on each side of joint-gap location.

**STEP 4: Clean Underside of BG and Install BG into Wet Waterproofing Membrane Mastic**

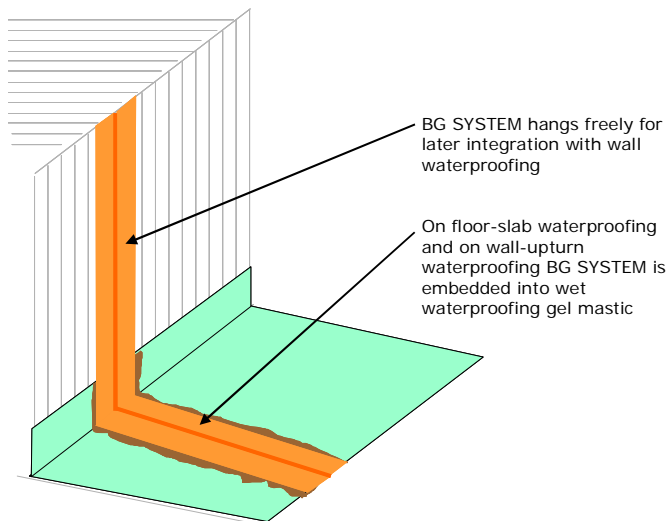

Clean the underside of the BG SYSTEM side sheets using solvent and clean, lint-free rags.

Note: Hang BG SYSTEM for walls freely for later integration with the waterproofing membrane to be installed on the walls.

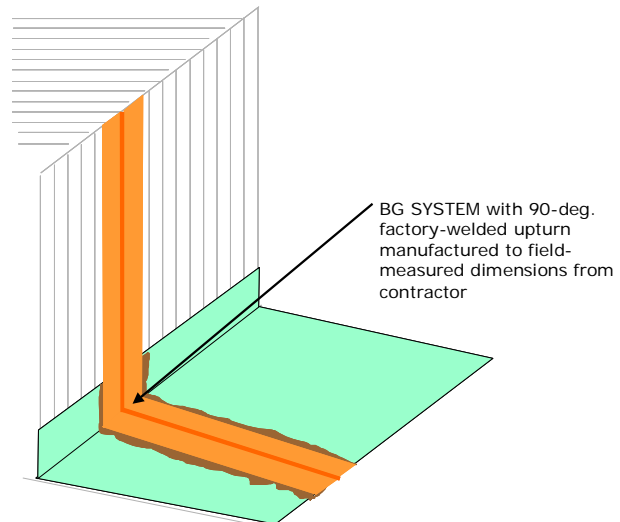

Install the BG SYSTEM so that the belly of the gland is centered over the joint-gap location.

Press or roll the BG SYSTEM flashing sheets firmly into the wet waterproofing membrane adhesive mastic being sure that outside corner of the upturn is also firmly embedded in the waterproofing membrane adhesive mastic.

Note: 90° transitions to the vertical are shipped as factory-welded upturns manufactured to field-measured dimensions by contractor. Ensure that these upturns have been ordered and delivered and are on site before starting installation.

**STEP 5: Apply Mastic Over Top of BG Side Sheets**

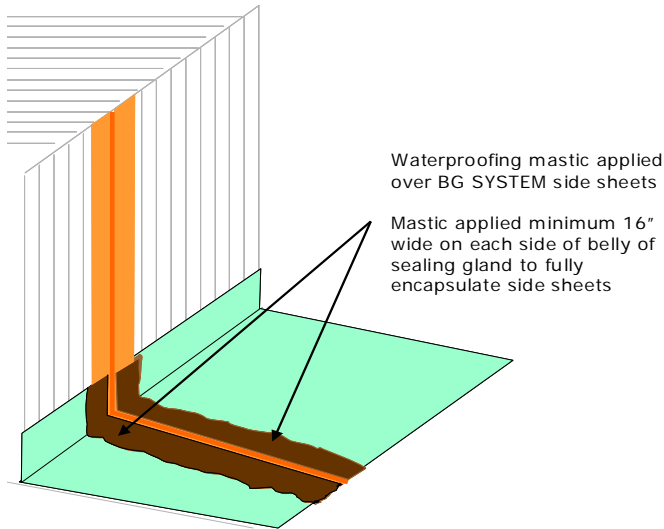

Clean the exposed upper side of the BG SYSTEM side sheets with toluene or xylene and clean, lint-free rags.

Apply waterproofing membrane mastic over the exposed upper side of BG SYSTEM side sheets to fully encapsulate them.

Note: Mastic applied minimum 16" wide on each side of belly of sealing gland to fully encapsulate side sheets

**STEP 6: Apply Full-Width Sheet of Waterproofing Membrane Over Mastic and BG**

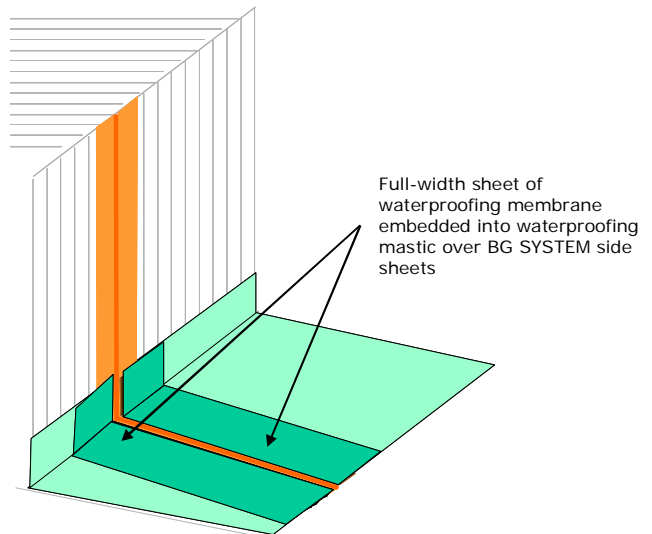

Roll out full-width sheet of waterproofing membrane into wet waterproofing membrane mastic on top of BG SYSTEM side sheets.

**STEP 7: Install Termination Bar and Anchors**

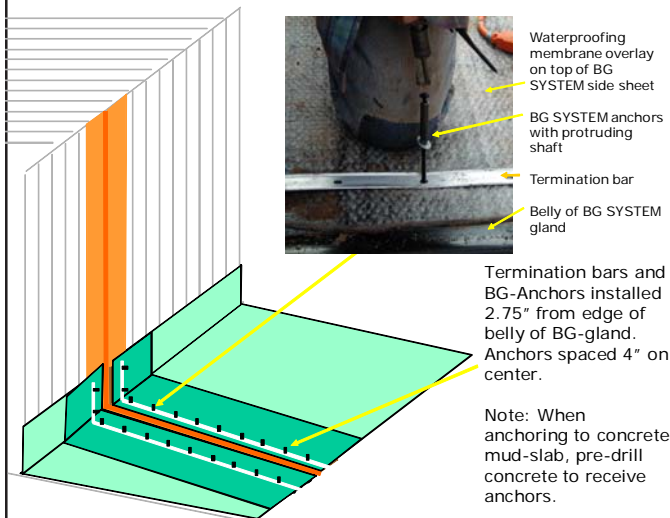

Install termination bars on both sides of the belly of the BG-gland with BG-Anchors spaced 2.75-inches (70 mm) from edge of belly of BG-gland.

Space anchors at 4-inches (100 mm) on center--one anchor per hole in the supplied termination bar.

Note: When anchoring to concrete, predrill concrete using 3/16-inch (5 mm) diameter, concrete drill bit to receive anchors.

**STEP 8: If Applicable: Field-weld BG to MIGUTAN FP1 10/25 on Free-standing Walls**

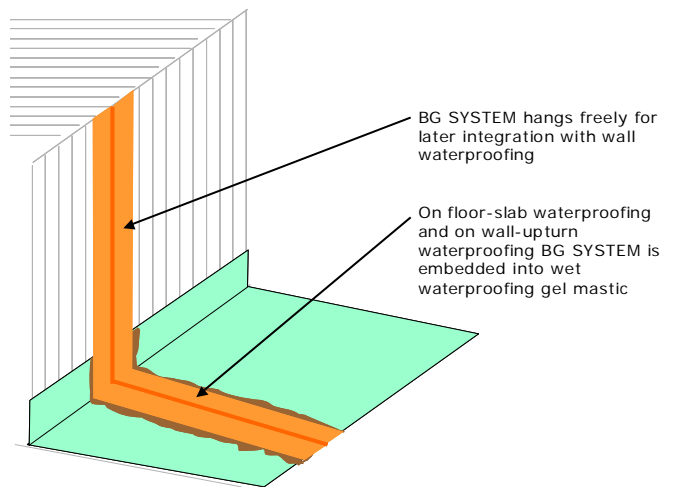

Note: If transitioning from underslab to freestanding walls, leave a free length of BG for welding to MIGUTAN FP1 10/25 gland and side sheets on freestanding wall.

**STEP 9: Install Waterproofing Membrane on Walls & Apply Mastic Beneath BG Side Sheets**

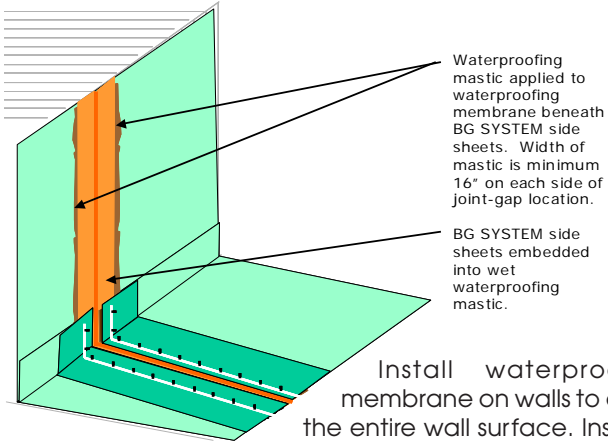

Waterproofing mastic applied to waterproofing membrane beneath BG SYSTEM side sheets. Width of mastic is minimum 16" on each side of joint-gap location.

BG SYSTEM side sheets embedded into wet waterproofing mastic.

Install waterproofing membrane on walls to cover the entire wall surface. Install in accordance with waterproofing membrane manufacturer's procedures and instructions.

Note: Ensure that a full-width sheet of waterproofing membrane is installed centered over the centerline of the expansion joint location. If a seam between previously installed waterproofing membrane is within 2-feet of the expansion joint centerline, then install another full sheet of waterproofing membrane centered over the expansion joint centerline.

Apply waterproofing membrane adhesive mastic to the waterproofing membrane beneath BG side sheets on wall. Width of waterproofing membrane adhesive mastic to be such that it extends a minimum of 2-inches (50 mm) beyond the edge of the flashing sheet (approximately 16-inches (410 mm) total) each side of joint-gap location.

Firmly embed BG SYSTEM side sheets into wet waterproofing membrane mastic by pressing or rolling.

**STEP 10: Apply Mastic Over Exposed Surface of BG Side Sheets on Walls**

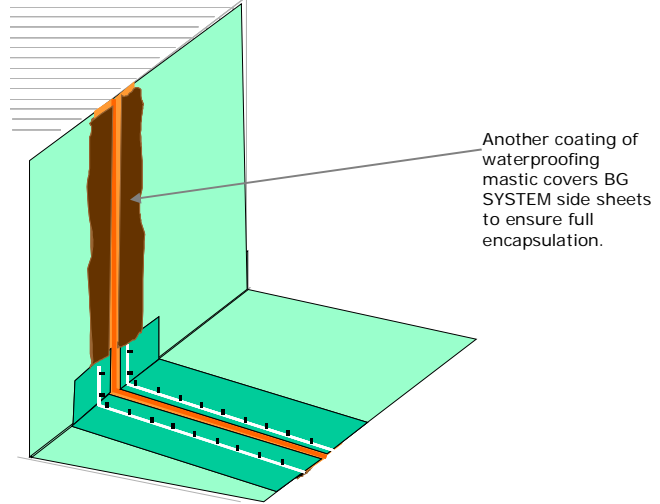

Another coating of waterproofing mastic covers BG SYSTEM side sheets to ensure full encapsulation.

Clean the exposed upper side of the BG SYSTEM side sheets with solvent and clean, lint-free rags to remove all dirt, debris and other contaminants.

Apply another coating of waterproofing membrane adhesive mastic over the top of the BG SYSTEM side sheets to ensure full encapsulation.

**STEP 11: Apply Waterproofing Membrane over Mastic and BG and Install Termination Bar and BG-Anchors**

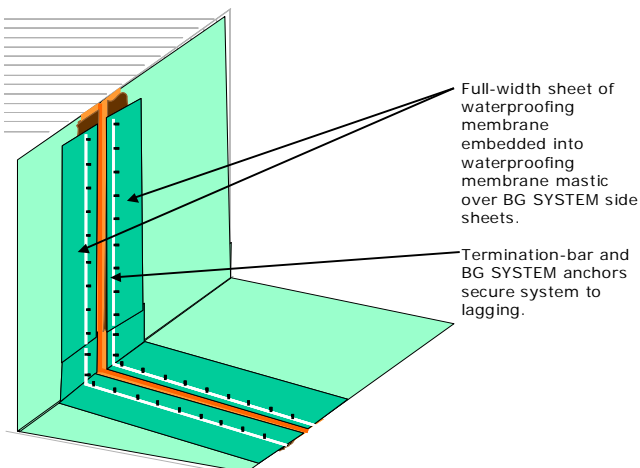

Full-width sheet of waterproofing membrane embedded into waterproofing membrane mastic over BG SYSTEM side sheets.

Termination-bar and BG SYSTEM anchors secure system to lagging.

Apply a full-width sheet of waterproofing membrane into wet waterproofing membrane mastic on top of BG SYSTEM side sheets.

Install termination-bar and BG SYSTEM anchors to lagging. Note: In lagging, screws can be driven without predrilling.

**STEP 12: Set Forms or Bulkheads to Cast Joint-Gaps**

Note: Steps 12 through 16 are usually the responsibility of the General Contractor or Concrete Sub-Contractor and may be job specific and may vary. Coordination with the waterproofing subcontractor for completion of the BG SYSTEM installation, as well as the actions of GC in protecting the in-place system components, during these steps is critical.

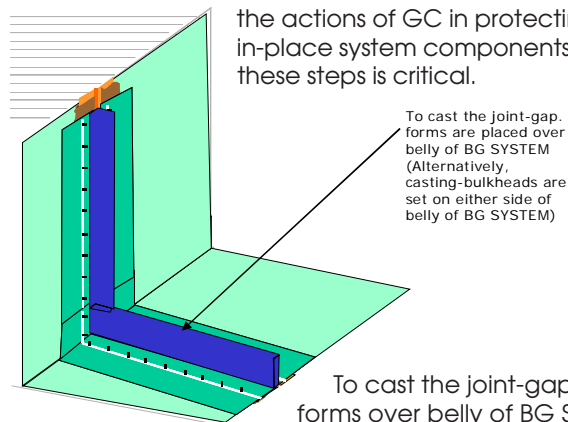

To cast the joint-gap, forms are placed over belly of BG SYSTEM (Alternatively, casting-bulkheads are set on either side of belly of BG SYSTEM)

To cast the joint-gap, place forms over belly of BG SYSTEM.

(Alternatively, set casting-bulkheads on either side of belly of BG SYSTEM ensuring that the belly is not crushed and the BG SYSTEM/waterproofing membrane sandwich is not damaged).

**STEP 13: Set Rebar Adjacent to Forms as Required**

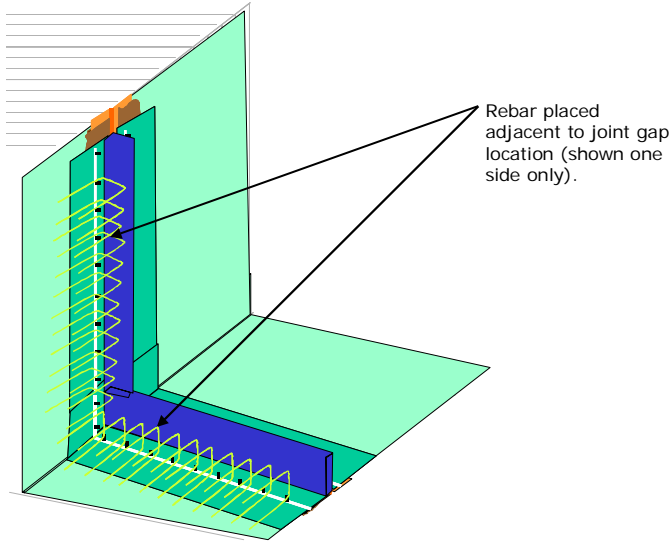

Place rebar adjacent to joint gap location as required.

**NOTE:** Rebar installation and concrete placing schedules vary from project to project. The principles of installation and protection of the BG SYSTEM and waterproofing membrane system must be understood and respected by all trades regardless of schedule.

**STEP 14: Place Concrete for Floor Slabs**

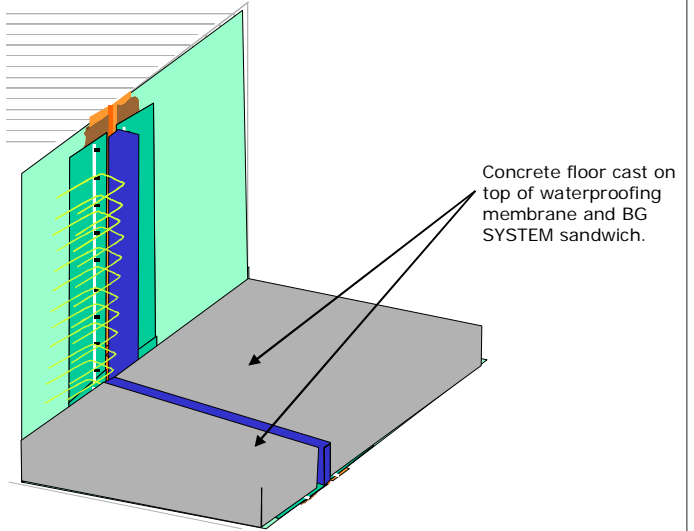

Cast concrete floor on top of waterproofing membrane and BG SYSTEM sandwich.

**STEP 15: Place Concrete for Wall Slabs**

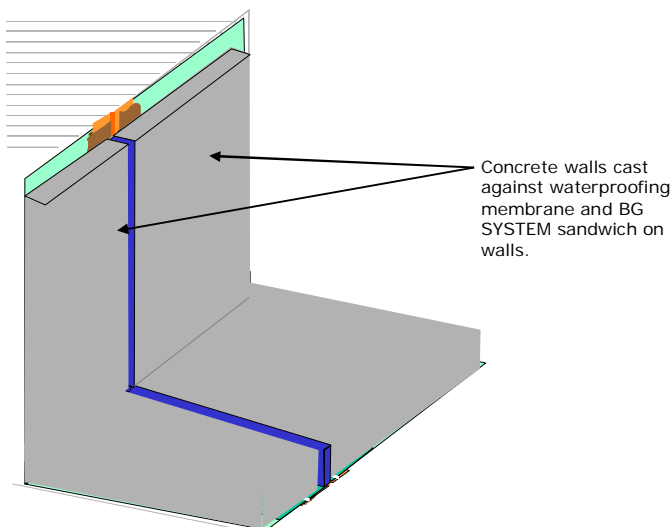

Cast concrete walls against waterproofing membrane and BG SYSTEM sandwich on walls.

**STEP 16: Align Roof Joint-Gap Forms and Place Concrete for Roof Slabs**

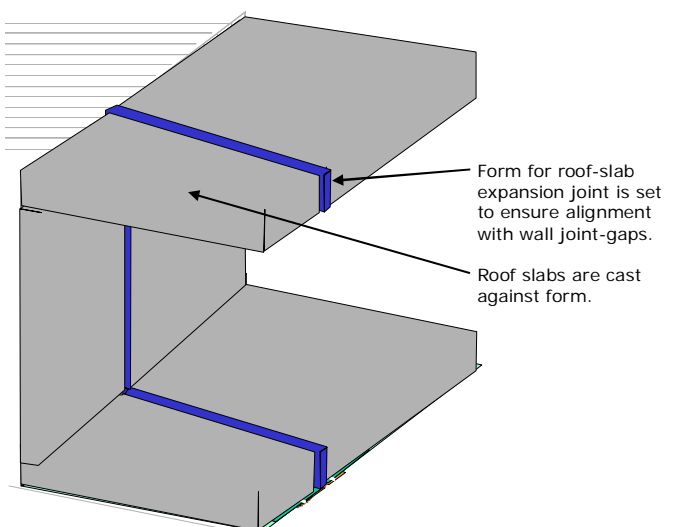

Set form for roof-slab expansion joint to ensure alignment with wall joint-gaps.

**STEP 17: Remove Joint-Gap Forms**

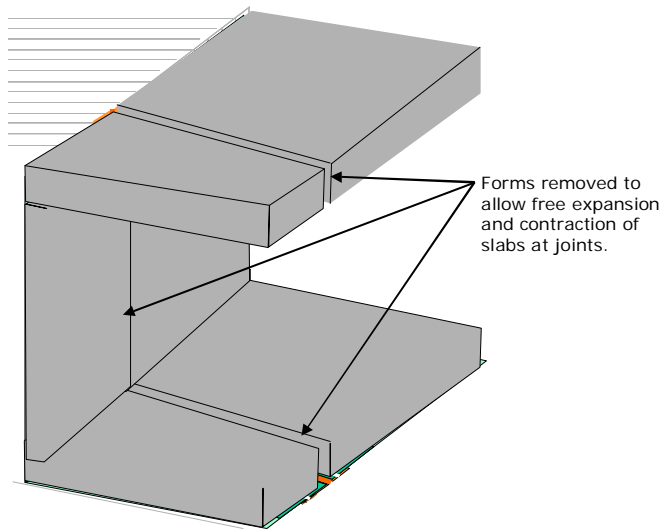

Remove forms from joint-gaps to allow free expansion and contraction of slabs at joints.

**STEP 18: Weld BG into MIGUTAN on Roof**

Field-weld the factory-fabricated outside-corner transition between BG SYSTEM and MIGUTAN plaza deck joint system.

Install the MIGUTAN plaza deck joint system in accordance with complete MIGUTAN installation instructions available from EMSEAL.

**IMPORTANT:** If there is no joint in the foundation floor slab, AND wall and foundation waterproofing wraps the entire structure, AND the BG SYSTEM is being installed against the blind side walls only, then the BG SYSTEM installed into wall joints and encapsulated into waterproofing sandwich must extend beyond the finished (interior) floor slab elevation and well into drainage course. If this is not done, any water collected by the BG SYSTEM could be funneled into the structure at the wall to floor-slab connection.

Note:

