



MIGUTAN FP 110

(Previously FP 90, name changed as part of metric standardization program)

Watertight, Plaza Deck, & Split Slab Expansion Joint

TECH DATA

Manufacturer:

EMSEAL JOINT SYSTEMS, LTD

25 Bridle Lane
Westborough, MA 01581-1228
PH: 508-836-0280 TOLL FREE: 1-800-526-8365 FX: 508-836-0281

EMSEAL, LLC

120 Carrier Drive
Toronto, Ontario, Canada M9W 5R1
PH: 416-740-20110 FX: 416-740-0233

Product Description

- MIGUTAN (mig-yoo-tan) consists of heavy-duty extruded aluminum retainer rails, synthetic rubber side flashing sheets, a thermo-plastic rubber sealing insert, and stainless-steel retainer caps.
- The rails are bolted to the structural slab, the flashing sheets are integrated in a sandwich with the deck waterproofing system.
- The sealing insert is installed over the upper end of the flashing sheets and is held in compression by the stainless-steel retainer caps.
- The net result is a system that integrates the structural slab, deck waterproofing and expansion joint system which is essentially independent of the wear-course components (ex: pavers, asphalt topping, concrete topping, etc.) while ensuring that movement is properly accommodated.

Uses, Applications

- Plaza Decks
- Split-Slab Parking Decks
- Roof Decks
- Below-Grade Deck and Wall Joints

SYSTEM FEATURES (IN ORDER OF INSTALLATION)

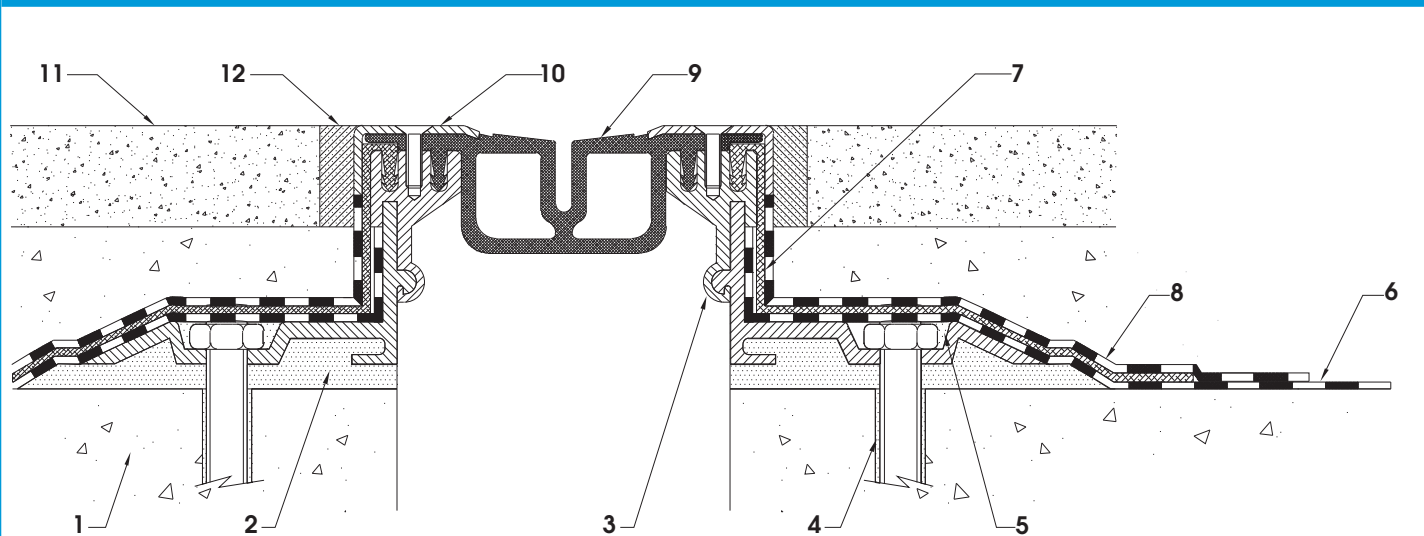

KEY to SYSTEM FEATURES

- | | | |
|--|---|--|
| <p>1- STRUCTURAL SLAB</p> <p>2- EPOXY LEVELLING BED ENSURES THAT RETAINER LEGS ARE FULLY SUPPORTED WHILE ACTING AS A DIELECTRIC SEPARATOR</p> <p>3- TWO OR THREE PIECE INTERLOCKED RETAINER LEGS ARE FREE TO SLIDE RELATIVE TO EACH OTHER TO PROVIDE POSITIVE INTERLOCKING OF SUCCESSIVE JOINT LENGTHS. (NOTE: Solid-leg FP 110/6000S & FP 110/25 interlocked by means of stainless-steel connector pins)</p> <p>4- 3/8" x 4" (8mm x 100mm) EPOXY ANCHORS AT 12-inch (300mm) CENTERS ENSURE SECURE</p> | <p>5- LEVEL-FILLED ANCHOR CHANNELS PROTECT WATERPROOFING FROM DAMAGE</p> <p>6- DECK WATERPROOFING IS INSTALLED ACROSS DECK AND UP MIGUTAN RETAINER LEG</p> <p>7- HEAT-WELDABLE, HIGH-NITRILE PVC SIDE FLASHING SHEETS ARE FULLY EMBEDDED IN, WELDED TO OR ADHERED TO UPPER SURFACE OF PRIMARY DECK WATERPROOFING</p> <p>8- OVERLAY AND DECK MEMBRANES ENCAPSULATE MIGUTAN FLASHING SHEET IN</p> | <p>9- WATERTIGHT SANDWICH HEAT-WELDABLE SEALING GLAND ALLOWS FOR WATERTIGHT HEAT-WELDED TRANSITIONS IN DIRECTION AND PLANE</p> <p>10- STAINLESS-STEEL RETAINING CAPS AND MACHINE-SCREWS CLAMP SEALING GLAND AND FLASHING SHEET AND ARE REMOVABLE FOR SEAL MAINTENANCE</p> <p>11- PAVERS, ASPHALT, FILL, OR OTHER WEAR-SURFACE</p> <p>12- SELF-LEVELLING, TRAFFIC-GRADE SEALANT CONTROL JOINT (as needed to suit application--Consult EMSEAL)</p> |
|--|---|--|

LOAD CAPACITY

Plaza and Parking Decks: FP 110/45 - FP 110/115: Suitable for slow moving vehicles with pneumatic tires such as cars and light trucks up to 16,860 lb.wt. (75 kN) gross.

Ramps, Loading Docks or other Decks with Continuous Heavy-Duty (Truck, Bus) Vehicular Traffic: Use FP 110/6000S or newly available steel legs--Consult EMSEAL.

SELECTION GUIDE

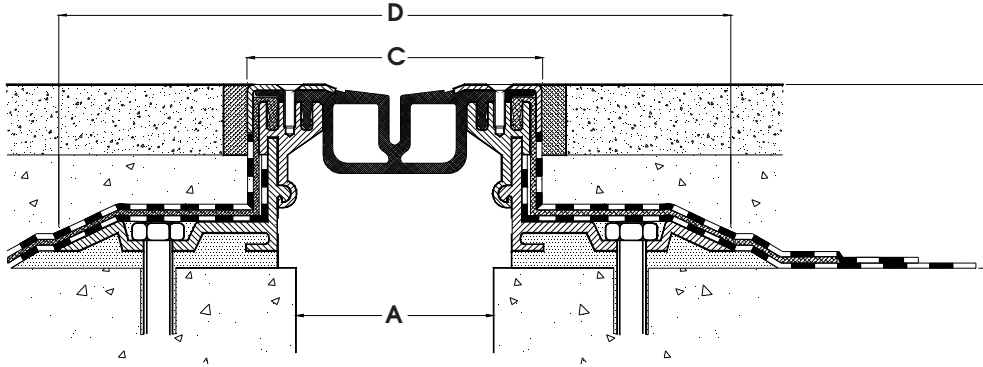

Model No.	For Mean Temperature Joint Size of up to A	Total Movement Capability (over total expected T° Range)	C Exposed Width (at mid-point of movement range)	D Overall Width (At mid-point of movement range)	E Height
-----------	---	--	---	---	-----------------

For transitions to the vertical plane, below-grade joints, and parking decks with normal car traffic and occasional truck/bus traffic:

FP 110/25	2.36" (65mm)	2.00" (50mm)	4.33" (110mm)	9.05" (230mm)	0.98" (25mm)
-----------	--------------	--------------	---------------	---------------	--------------

For split-slab parking and plaza decks with normal car traffic and occasional truck/bus traffic:

FP 110/45	3.00" (76mm)	2.36" (60mm)	4.33" (110mm)	9.33" (237mm)	1.81" (46mm)
FP 110/60					2.44" (62mm)
FP 110/80					3.19" (81mm)
FP 110/95					3.81" (97mm)
FP 110/115					4.61" (117mm)

For split-slab parking and plaza decks with continuous heavy-duty (truck/bus) traffic:

FP 110/6000S	2.00" (50mm)	2.36" (60mm)	4.33" (110mm)	9.05" (230mm)	2.36" (60mm)
--------------	--------------	--------------	---------------	---------------	--------------

For non-vehicular-traffic plaza decks. Extra-high leg heights accommodate thick overlay systems and topping slabs. These models are supplied with extra-long (double-width) side sheets to ensure proper integration with deck waterproofing.

FP 110/130	3.00" (76mm)	2.36" (60mm)	4.33" (110mm)	9.33" (237mm)	5.12" (117mm)
FP 110/150					5.90" (150mm)
FP 110/165					6.57" (167mm)
FP 110/185					7.36" (187mm)
FP 110/200					7.95" (202mm)
FP 110/220					8.74" (222mm)
FP 110/235					9.33" (237mm)
FP 110/255					10.12" (257mm)
FP 110/270					10.71" (272mm)
FP 110/2110					11.49" (292mm)
FP 110/305	12.09" (307mm)				

NOTE: STEEL LEGS ARE NOW AVAILABLE FOR INCREASED LOADING CAPACITY FOR ALL LEG HEIGHTS: Contact EMSEAL.

Production length of metal parts: 13.12 LF (4 meters).

Side flashing sheets available in rolls up to 65.6 LF (20 meters).

Sealing gland available in continuous lengths practicable to shipping and to suit job--Consult EMSEAL.

Watertight Transitions & Terminations

Factory-heat-welded thermoplastic-rubber sealing insert and heat-weldable side sheets as well as factory-welded aluminum components assure watertightness through transitions and terminations. Virtually any kind of transition is both possible and practical.

CAD Drawings & Guide Specs On Disk or By E-Mail

Guide specifications and CAD details are available on floppy disk or by e-mail. Please contact your local EMSEAL representative or call EMSEAL.

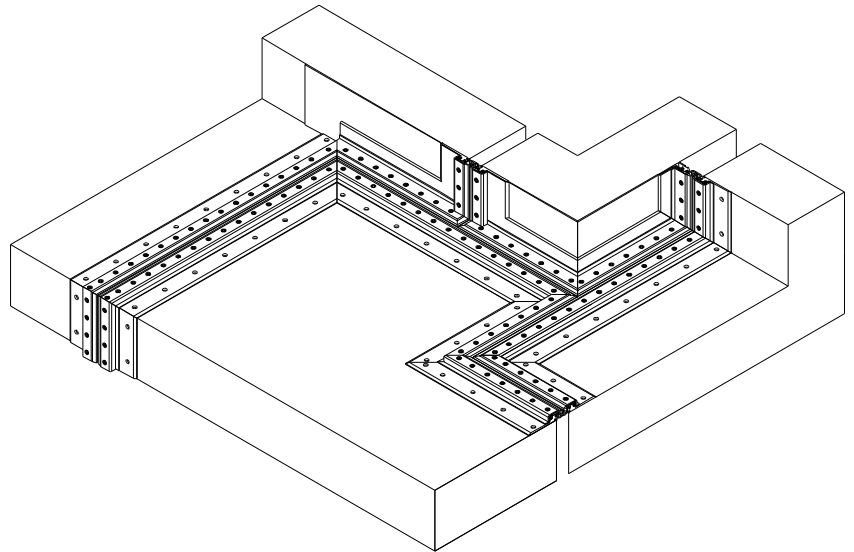

Transitions From Horizontal to Vertical Planes

Transitions to the vertical plane are commonly overlooked in design, manufacture and installation. These details are critical to watertightness and can be properly addressed by the MIGUTAN system with transition into other products by EMSEAL for waterproofing the joints in parapets, walls, split columns, etc.

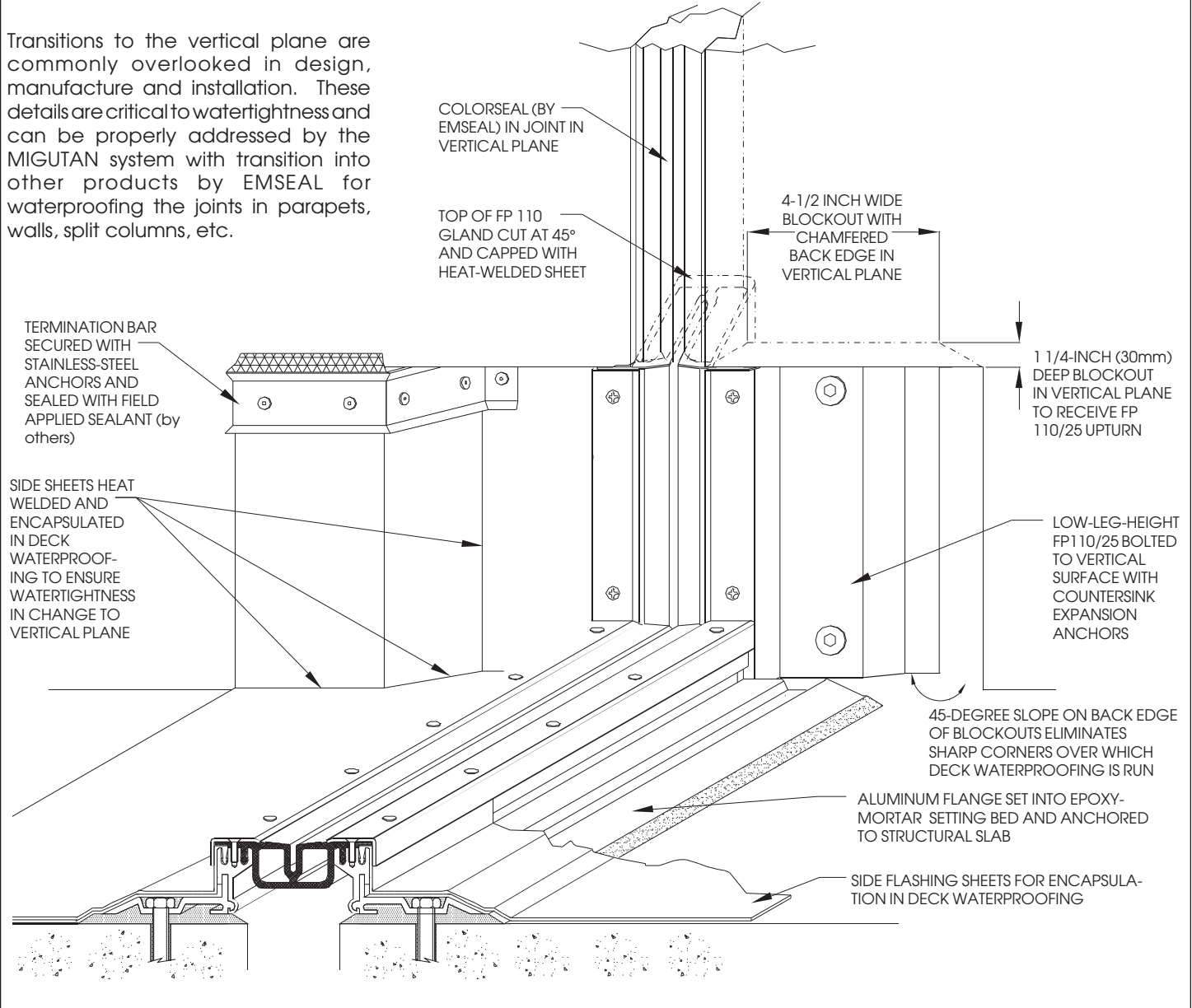

E-2 & E-8 DECK-TO-WALL OPTIONS (AVAILABLE FOR ALL MODELS)

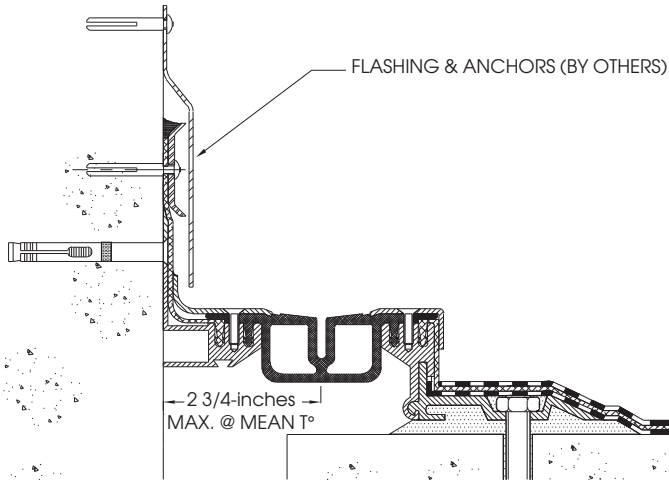

NOTE: Use E-2 where continuous runs of deck-to-wall joint are uninterrupted by columns or other elements adjacent to the run of the joint.

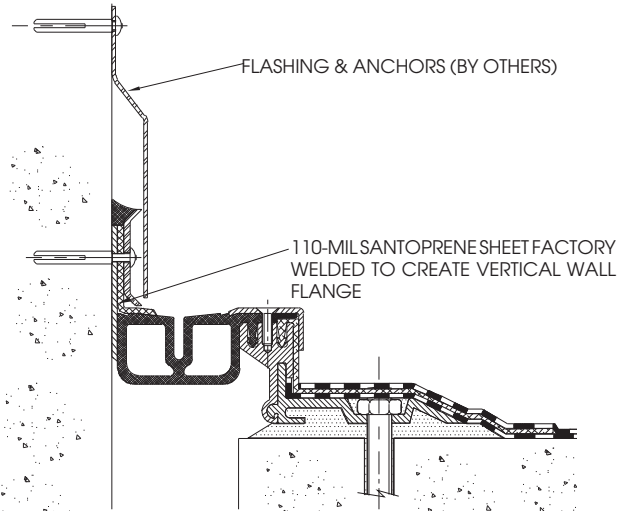

NOTE: Use E-8 where joint-gap alternates from deck-to-deck to deck-to-column or wall at intervals along the joint. The E-8, by removing the metal anchor bracket present in the E-2 version, eliminates the need to dog-leg around columns, walls, etc., that interrupt continuous runs.

FP 110/6000S (SOLID LEG FOR HEAVY-DUTY VEHICULAR TRAFFIC)

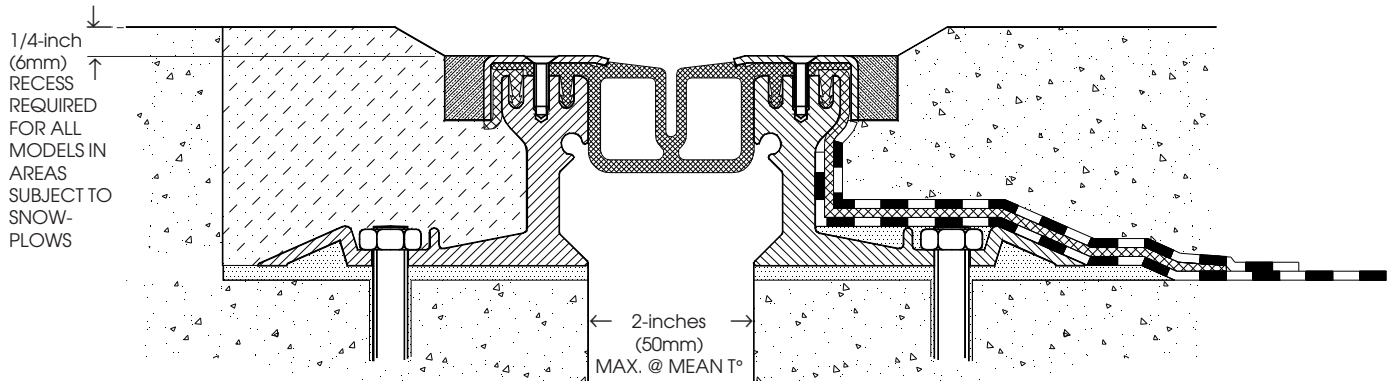

NOTE: Left side of detail shows installation in elastomeric concrete with short side flashing sheets where no deck waterproofing exists. Right side of detail shows installation with full side flashing sheets integrated with deck waterproofing membrane.

FP 110/...WITH OPTIONAL STAINLESS STEEL COVERPLATE

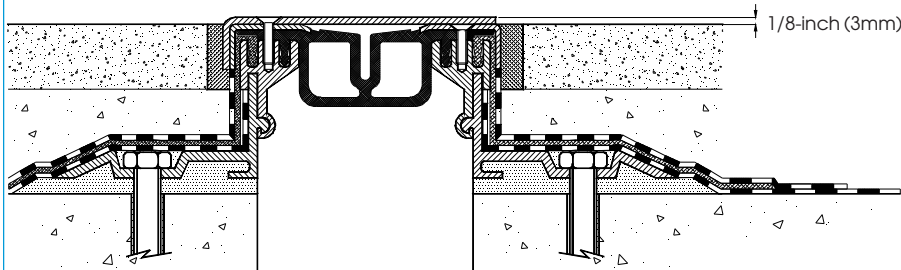

Integral coverplate is available at purchaser's preference as an optional extra. Coverplate can be made non-skid at purchaser's preference through the field-application of an abrasive coating after installation of the joint system.

Warranty

Standard or project-specific warranties are available from EMSEAL on request.

Availability & Price

EMSEAL products are available throughout the United States and Canada. Prices are available from local representatives or direct from the manufacturer. The EMSEAL product range is continually being updated. Accordingly, we reserve the right to modify or withdraw any product without prior notice.