



20H™ SYSTEM

TECH DATA

Manufacturer:

EMSEAL JOINT SYSTEMS, LTD.

25 Bridle Lane
Westborough, MA 01581
PH: 508-836-0280 TOLL FREE: 1-800-526-8365 FX: 508-836-0281

EMSEAL, LLC

120 Carrier Drive
Toronto, ON, Canada M9W 5R1
PH: 416-740-2090 FX: 416-740-0233

Product Description

- **20H** is a preformed expanding foam sealant produced by impregnating permanently elastic, high-density, open-cell polyurethane foam with water-based, polymer-modified asphalt.
- Partially filling the open-cells with the impregnation and then compressing the material results in levels of sealing depending on the degree of compression.
- Typically, approximately 5-times compression is required for watertightness in below-grade and horizontal deck applications.
- The **20H** foam is packaged precompressed in shrink-wrapped lengths (sticks).
- It is supplied precompressed to less than the nominal material size for easy insertion into the joint.
- Sealing between the foam and substrate is achieved through a combination of the effects of foam backpressure and the epoxy adhesive applied to the substrates and into which the **20H** foam is installed.
- The exposed or outer surface of the installed **20H** is further treated with TOPCOAT, supplied to suit the application.
- The complete **20H SYSTEM** comprises three elements: 1) the **20H** foam, 2) the epoxy adhesive, and 3) the TOPCOAT. See Figure 1.

Uses, Applications

- As a watertight seal in joints including:

Decks	Below-Grade
- structural joints	- foundation
- perimeter joints	- planters
- roadways	- tunnels
- sidewalks	
- parapets	

Other

- concrete covers on tunnels, wastewater tanks, etc.

- **20H** is generally used as a primary seal. As such it is usually installed flush to the deck or below-grade wall surface.
- **20H** can be used as a secondary seal and resilient support behind a bond breaker tape and caulking.

Figure 1: 20H SYSTEM in Typical Installation

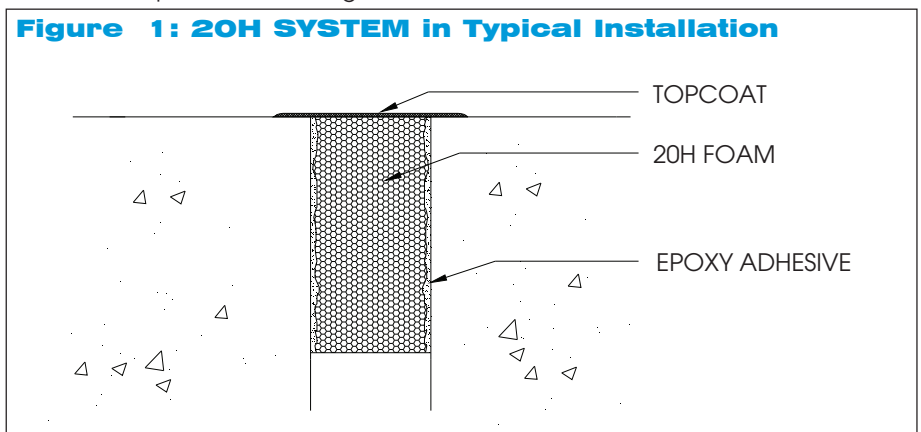

TABLE 1: Typical Physical Properties of 20H

Property	Value	Test Method
BASE MATERIAL	OPEN CELL, HIGH DENSITY, POLYURETHANE FOAM	N/A
Impregnation	Polymer-modified asphalt	N/A
COLOR	BLACK	N/A
Density (uncompressed)	9-10 lb/ft³ (144-160 kg/m³)	
DENSITY (COMPRESSED TO 20% OF UNCOMPRESSED WIDTH)	45-50 LB/FT ³ (720-800KG/M ³)	
Tensile strength	21 psi min (145 kPa)	ASTM D3574
ELONGATION - ULTIMATE	150% MIN	ASTM D3574
Temperature range		ASTM C711
High - permanent	185°F (85°C)	
High - short term	203°F (95°C)	
Low	-40°F (-40°C)	
SOFTENING POINT	140°F MIN (60°C)	ASTM D816
UV resistance	Excellent	
MILDEW RESISTANCE	EXCELLENT	
Resistance to aging	Excellent	
BLEEDING	NONE	
-40°F TO 180°F (-40°C TO 85°C)		
Compression set	3% max	ASTM D3574
70°C 50% RH after 72 hrs.		
THERMAL CONDUCTIVITY	0.34 BTU. IN/HR. FT ² .°F (0.05 W/M. °C)	ASTM C518
Low temperature flexibility	No cracking or splitting	ASTM C711
32°F to -10°F (0°C to -23°C)		
WATER VAPOR TRANSMISSION AT 25% COMPRESSION	0.011 PERMS	ASTM C355-64

- Suitable for use in substrates of brick, CMU, precast and cast-in-place concrete, wood, stone and most construction materials. (For suitability to a particular substrate, consult EMSEAL).

Advantages

- Resilient, traffic-durable primary seal system
- Permanently elastic and weather-tight
- Backpressure and resilience of **20H** provides support for the concrete joint edges
- In below-grade applications, **20H** provides a resilient bearing surface for below-grade waterproofing materials at joints
- Follows joint contours
- Difficult to vandalize
- Exposed face remains flat regardless of variation and changes in joint width and compression
- Resistant to de-icing salts
- Excellent thermal and sound insulating properties
- Vermin proof

Limitations

- **20H SYSTEM** will not adhere to joints that are dirty or dust-covered or to surfaces coated with oils or release agents.
- **20H SYSTEM** service temperature range is -40°F to 185°F (-40°C to 85°C).
- **20H** is not resistant to sustained contact with petroleum solvents, oils, selected waxes, active chlorine, heavy oxidized acids or strong lyes.

Joint Seal Characteristics

- Below-grade and horizontal deck applications generally require compression to approximately 20% of the material's original uncompressed dimension (i.e. 5-times compression).
- Table 1 gives the physical properties of **20H**.
- Table 2 illustrates standard sizing of **20H**.
- **20H** is rated for joint movement of +25%, -25% (total 50%) of nominal material width.

Joint Design

- Due to the rigorous conditions under which the **20H SYSTEM** is generally used, each application of the sys-

tem should be reviewed by EMSEAL. (See "Deck Expansion-Joint Checklist" in EMSEAL binder Section 1 or call EMSEAL.)

- Substrate faces must be parallel and have sufficient clear depth to fully support the **20H SYSTEM**.
- Substrate must be capable of resisting, without deflection, approximately 2.5 lb/in² (17 kPa) backpressure from the **20H**.

Installation

- Surface Preparation: Joint surfaces must be free from gross irregularities, loose particles, foreign matter such as dirt, dust, ice, snow, water, etc., and coatings such as grease, oil, release agents, lacquers, etc., that may be detrimental to the adhesion of the sealant. Sandblast or grind to achieve suitable substrates.
- **20H** should be stored indoors at room temperature. Recovery is quicker when warm and slower when cold.
- Mix epoxy primer and apply to joint-gap faces.
- Remove **20H** from protective packaging.
- Check supplied width against joint-gap width, then heat to open cells

and expand to just larger than joint-gap width.

- Apply epoxy primer in light coating to lower half of **20H**.
- Insert material into joint-gap and push down until flush with surface.
- Join consecutive lengths of material with a 45° miter. Cut miters with a power-miter saw.
- Mask off deck 1/4" (6mm) away from the joint edges and apply Topcoat with paint brush.

Install in accordance with fully detailed installation instructions which accompany each order. These are also available separately from EMSEAL.

Warranty

Standard or project-specific warranties are available from EMSEAL on request.

Availability and Price

20H is available for shipment internationally. Prices are available from local representatives or direct from the manufacturer. The product range is continually being updated, and accordingly EMSEAL® reserves the right to modify or withdraw any product without prior notice.

TABLE 2: 20H Sizing

Product Code	Nominal Material Size (Joint Size At Mean T°)		Depth of Seal	
EH6040	1/2"	(12mm)	1-1/2"	(40mm)
EH7545	5/8"	(15mm)	1-1/2"	(40mm)
EH10050	3/4"	(20mm)	1-1/2"	(40mm)
EH12560	1"	(25mm)	2"	(50mm)
EH15060	1-1/4"	(30mm)	2"	(50mm)
EH19070	1-1/2"	(40mm)	2-1/2"	(65mm)
EH22570	1-3/4"	(45mm)	2-1/2"	(65mm)
EH25070	2"	(50mm)	2-3/4"	(70mm)
EH28080	2-1/4"	(55mm)	2-3/4"	(70mm)
EH30080	2-1/2"	(60mm)	3-1/8"	(80mm)
EH34090	2-3/4"	(70mm)	3-1/8"	(80mm)
EH37590	3"	(75mm)	3-1/2"	(90mm)

For sizes not listed consult EMSEAL.

NOTES:

- Select nominal material width to equal joint-gap width at mean temperature.
- Supplied in shrink-wrapped sticks of 6.56 LF (2M).

Printed with soy-based inks on acid-free, recycled, chlorine-free paper. 